

End of Life Plan

For

Kodak S3120 MAX & S3140 MAX Scanners

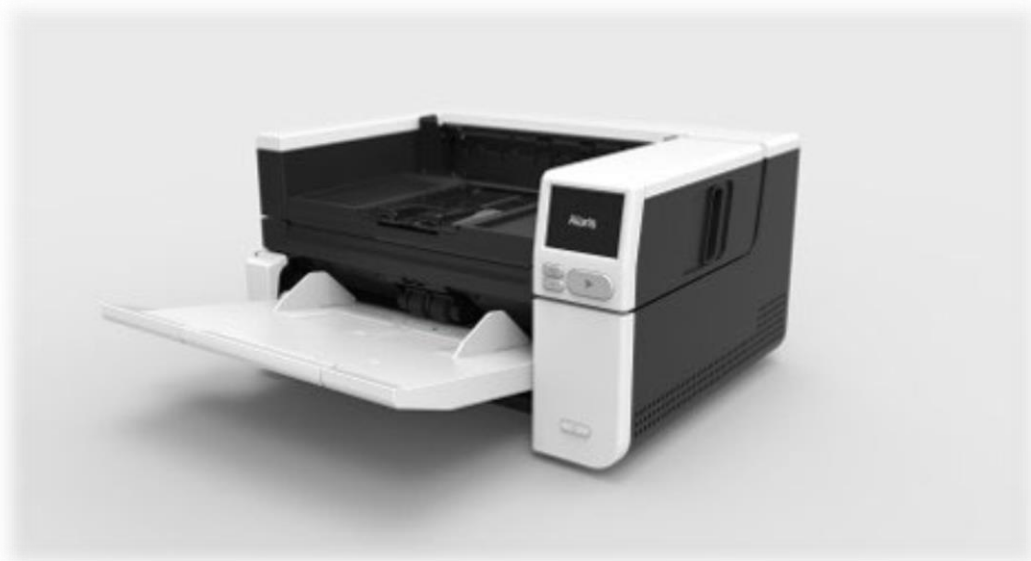

Compositional Analysis

This compositional analysis applies to the Kodak S2000f/S3000 Scanner Family. The following table identifies the location of materials that need special treatment by recyclers.

Material of concern	Present in part?	Describe Specific Component and/or location
External Battery	no	
Internal Battery	yes	CR 2032 coin-style lithium battery located on controller board
Asbestos	no	
Backlighting lamps	no	
Beryllium Oxide	no	
Other forms of Beryllium	no	
Cadmium	no	
Capacitors with PCB's	no	
Capacitors with substances of concern and height > 25 mm, diameter > 25 mm or proportionately similar volume	no	
Chromium VI	no	
Gas discharge lamps	no	
Lead	yes	Meets RoHS restrictions - however has components with exemptions; steel shaft, optical glass, wafer - high temp solder, Plug Adapter (copper alloy), gear in motor (copper alloy)
Liquid Crystal Displays with a surface area > 100cm ²	no	
Mercury	no	
Plastic containing brominated flame retardants	yes	Meets RoHS restrictions
Printed Circuit Boards >10 square centimeters	yes	See procedure for removal in this document
PVC/PVDC	yes	Harness insulation, cables, connectors...
Radio-active substances	no	
Refractory ceramic fibers	no	
Compartments / units / parts under pressure	no	
Compartments / units / contain liquids	no	
Compartments / units / contain gasses	no	
Compartments / units / contain "Hidden" mechanical springs or other equivalent parts	no	
Lasers	no	

Scanner Disassembly Instructions.

Remove the Output Tray Assy

[1] Move the EDGE GUIDES in.

[2] Remove the *Phillips* SCREW from the LEFT and RIGHT COVER HINGES.

[3] Remove the COVER HINGES.

Note: The OUTPUT TRAY should be flat.

[4] Push the OUTPUT TRAY back, then lift the BOTTOM of TRAY to remove it.

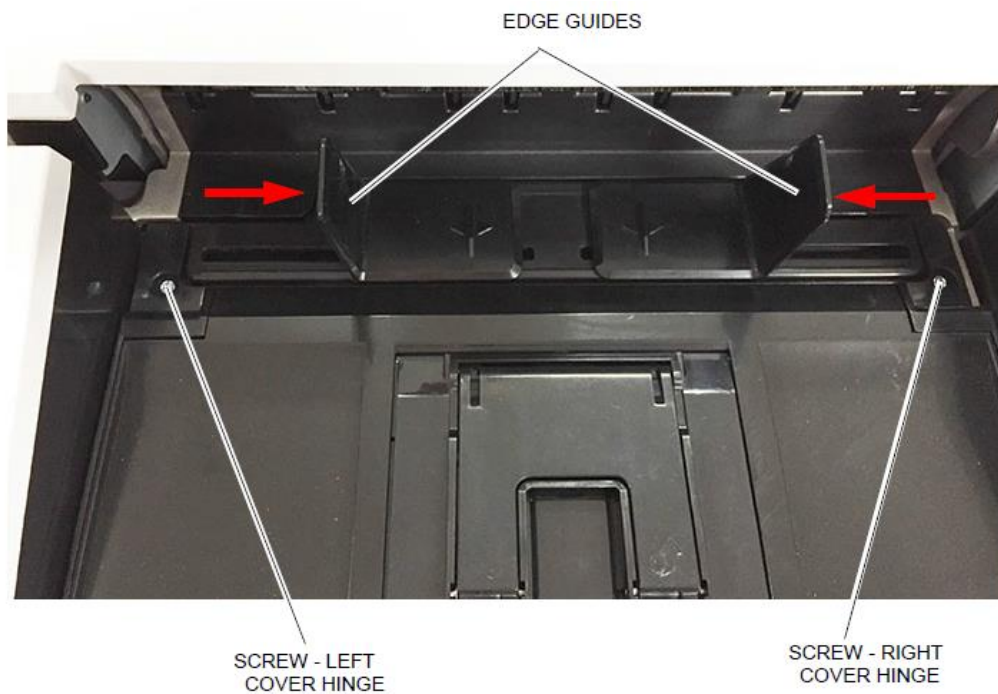

Remove the Back Panel

[1] Remove:

- two SCREWS with WASHERS
- BACK PANEL

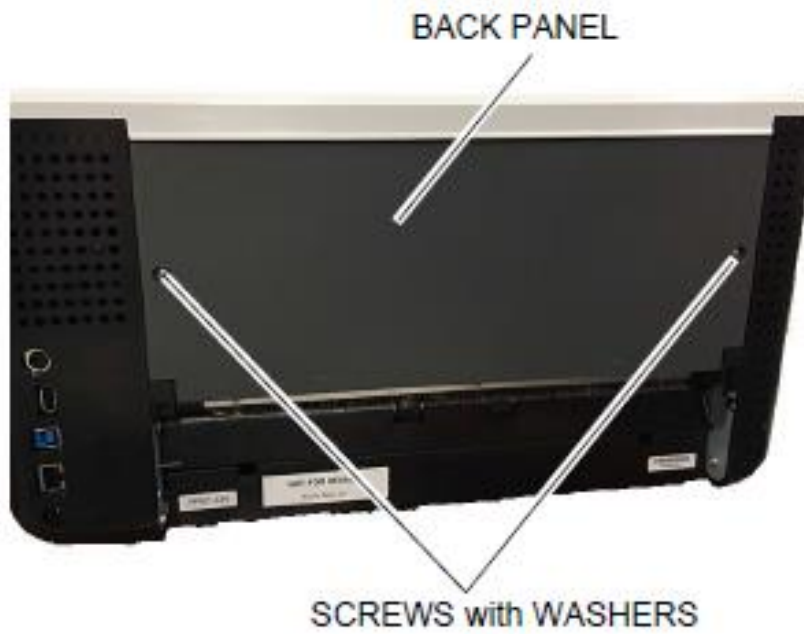

Remove the Top Cover

[1] Loosen the two SCREWS.

[2] Remove the TOP COVER.

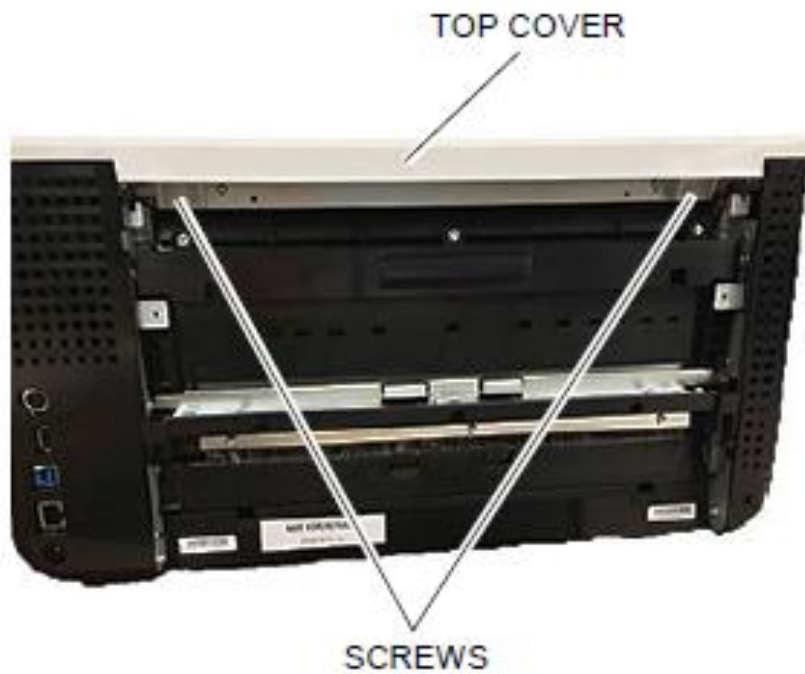

Remove the Left Cover

- [1] Manually move the INPUT TRAY (ELEVATOR) down to the "Home" position.
- [2] Pull out and remove the GAP RELEASE HANDLE. (As needed, use a screwdriver to pry the HANDLE.)

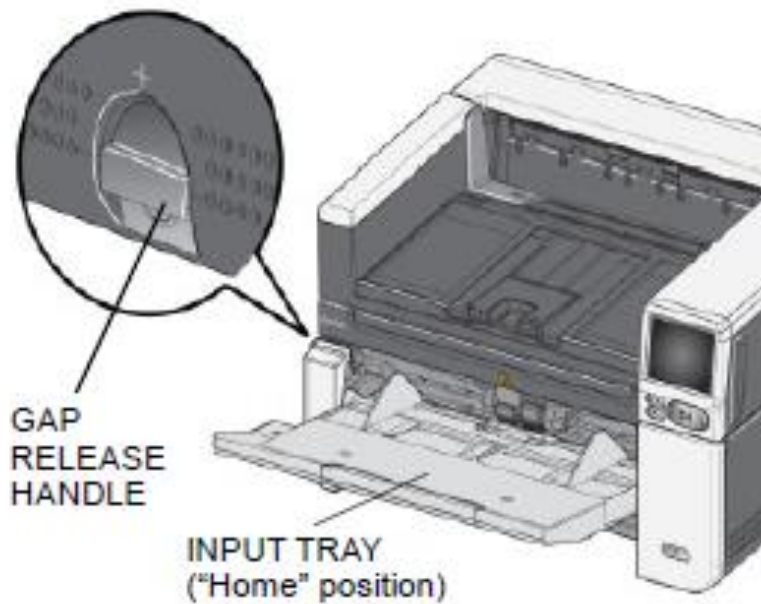

- [3] Open the POD.
- [4] Remove the T-20 SCREW.



[5] Manually move the INPUT TRAY (ELEVATOR) up to access the SCREW.

[6] Remove the T-20 SCREW.

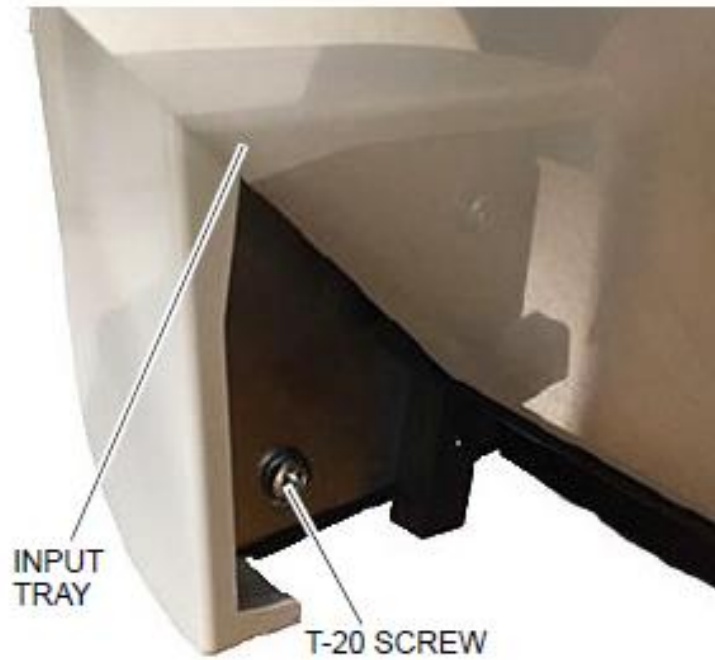

[7] Remove two T-20 SCREWS at the back of the SCANNER.

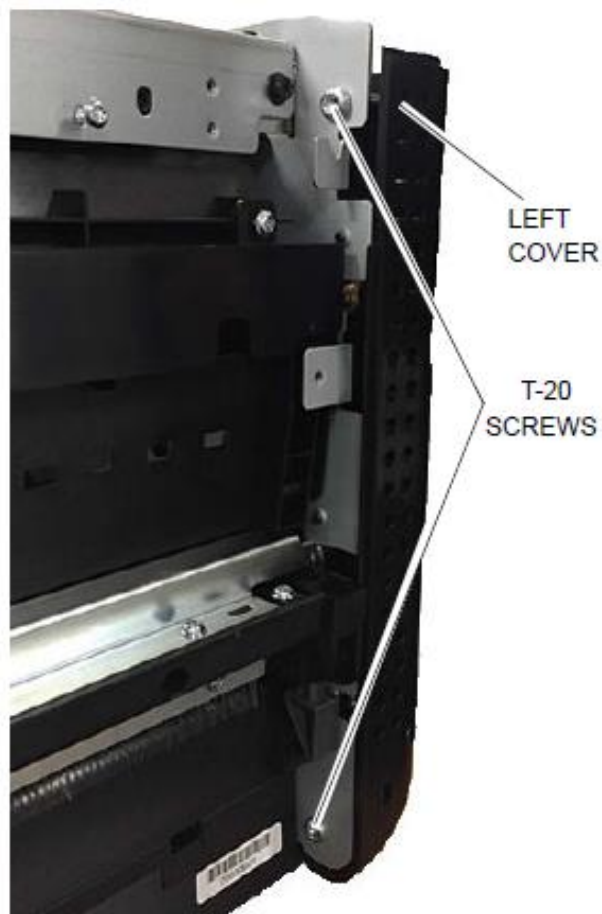

[8] Open the POD.

- [9] Remove:
- T-20 SCREW
 - LEFT COVER

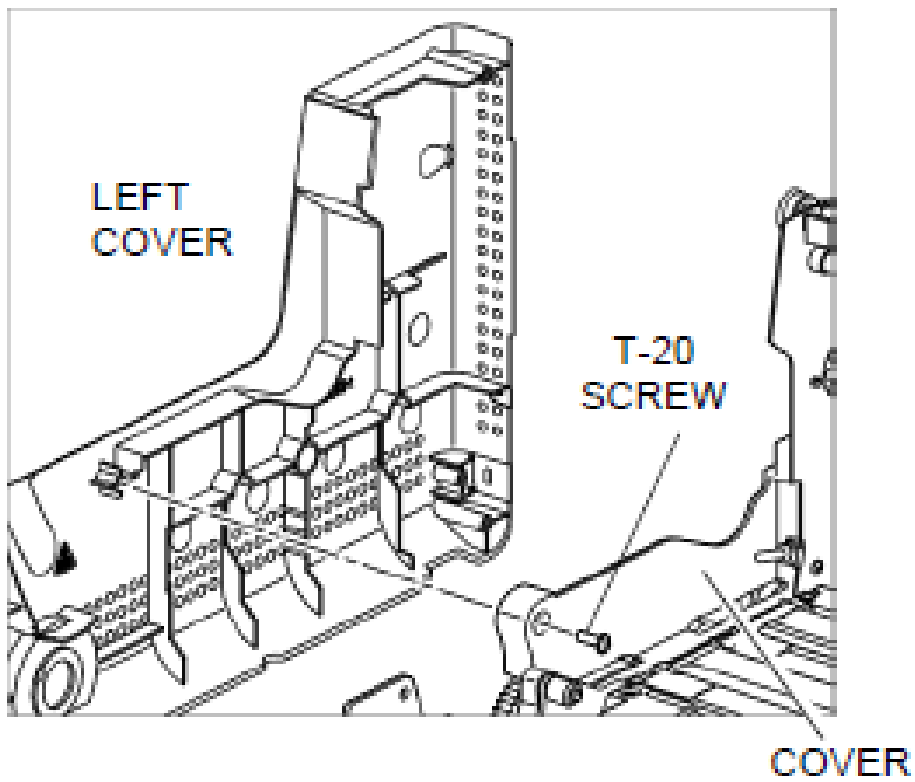

Remove the Right Cover

- [1] Manually move the INPUT TRAY (ELEVATOR) down to the “Home” position.
- [2] Open the POD.
- [3] Remove the T-20 SCREW.



- [4] Manually move the INPUT TRAY (ELEVATOR) up to access the SCREW.
- [5] Remove the T-20 SCREW.

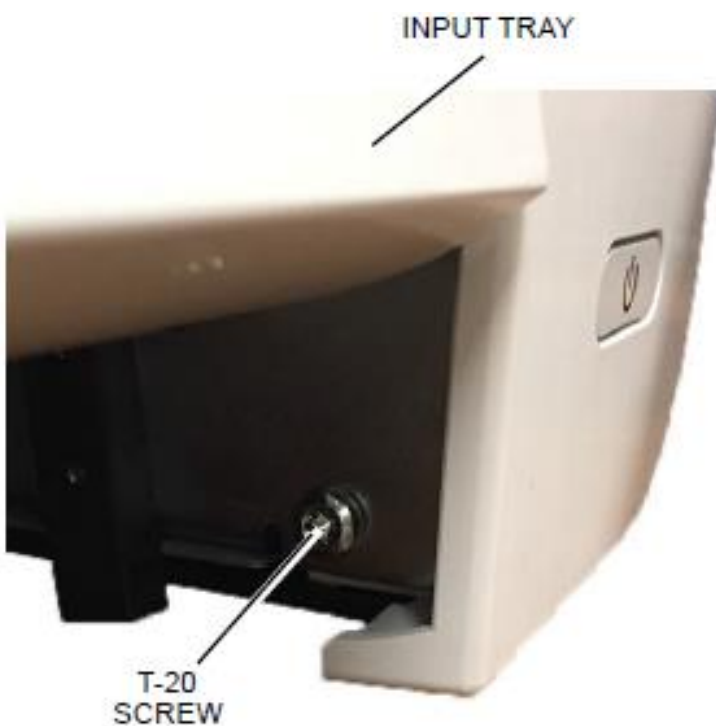

[6] Remove the two T-20 SCREWS at the back of the SCANNER.

[7] Remove the RIGHT COVER.



Remove Output Tray Assembly

Note: Important – The OUTPUT TRAY ASSY includes the FRAME and TRAY.

[1] Open the POD.

[2] Remove four T-10 SCREWS - silver.

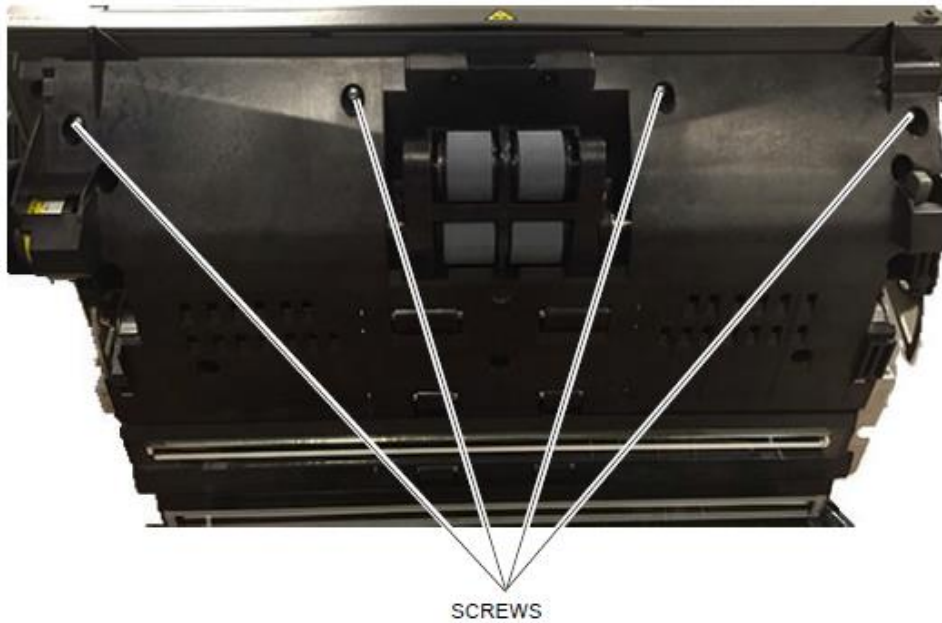

[3] Remove the T-10 SCREW - silver (left side of FRAME).



[4] Remove the T-10 SCREW - silver (right side of FRAME).

[5] Remove the OUTPUT TRAY ASSY from the SCANNER.



Remove the Integrated Flatbed Scanner (if installed)

[1] Open the POD.

[2] Remove four SCREWS.

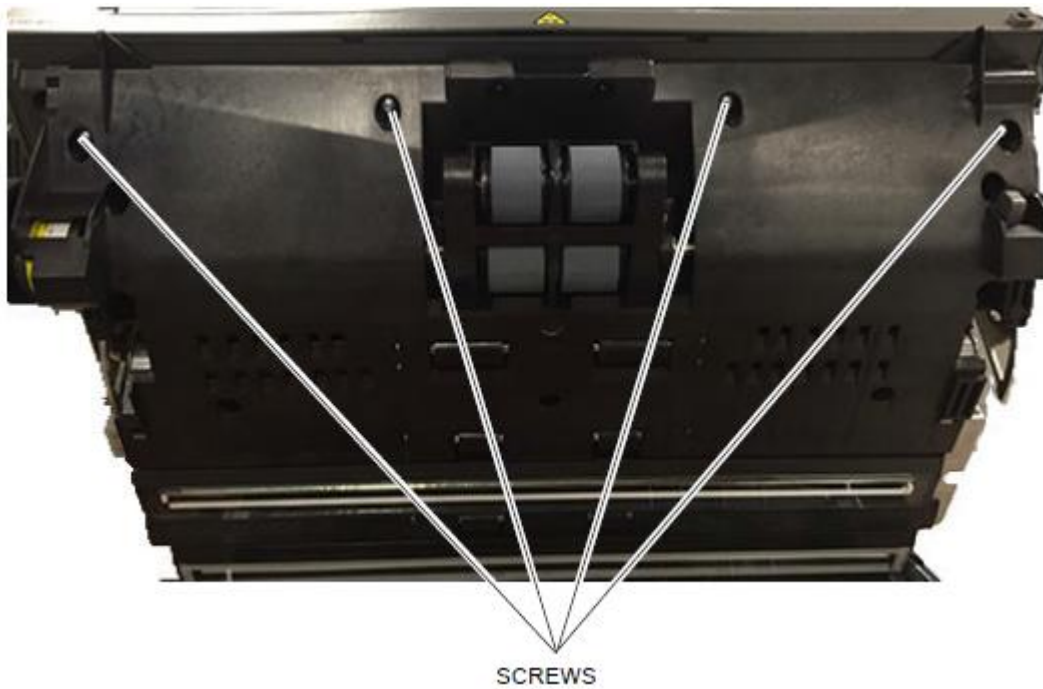

[3] Remove the SCREW (left side of FLATBED SCANNER).



[4] Remove the SCREW (right side of FLATBED SCANNER).

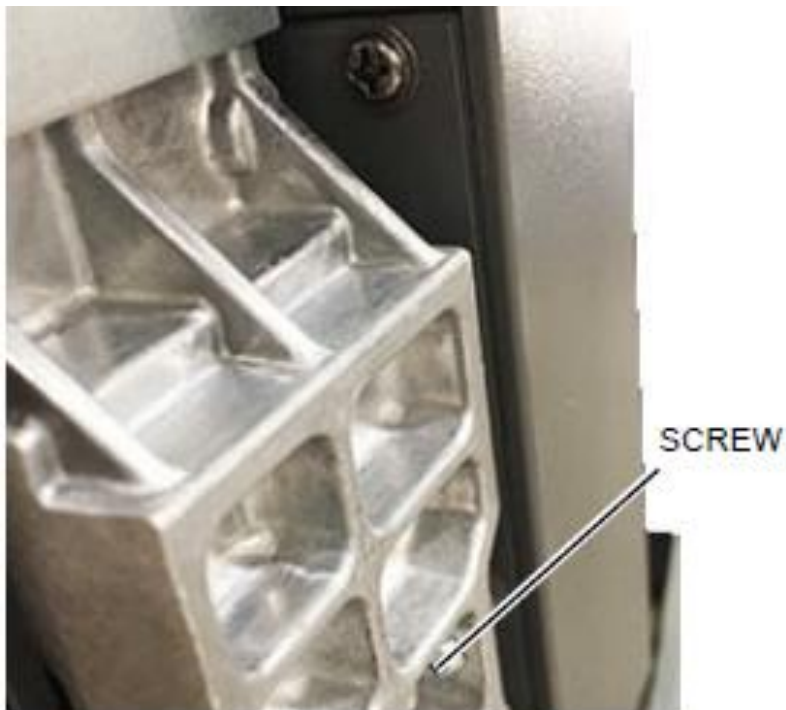

[5] Disconnect the:

- CABLE
- POWER CORD

[6] Remove the INTEGRATED FLATBED SCANNER.

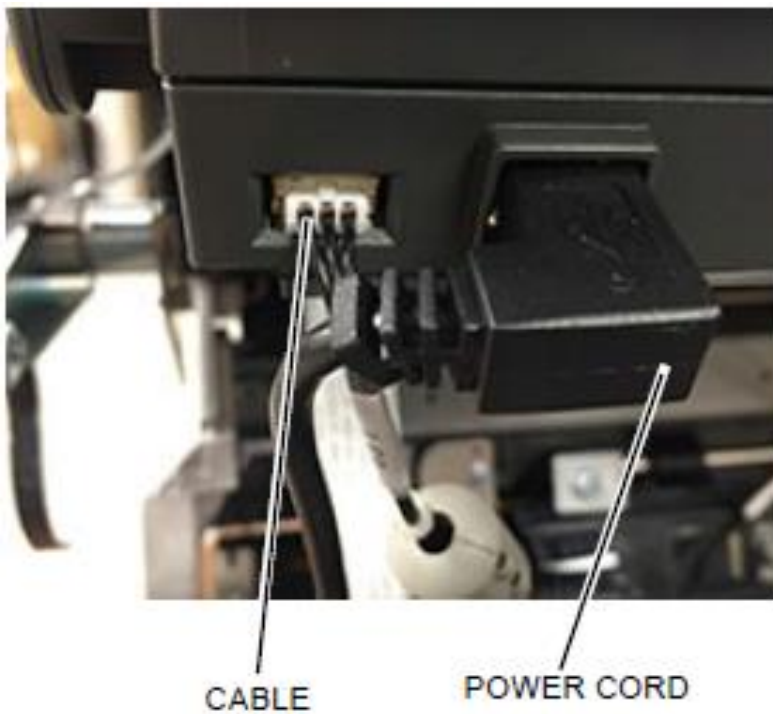

Remove the Input Tray

- [1] Open the POD.
- [2] Remove the two T-10 SCREWS* and BRACKET.
- [3] Remove the two T-20 SCREWS.
- [4] Remove the FLAG (elevator down).
- [5] Lift the INPUT TRAY to remove it.

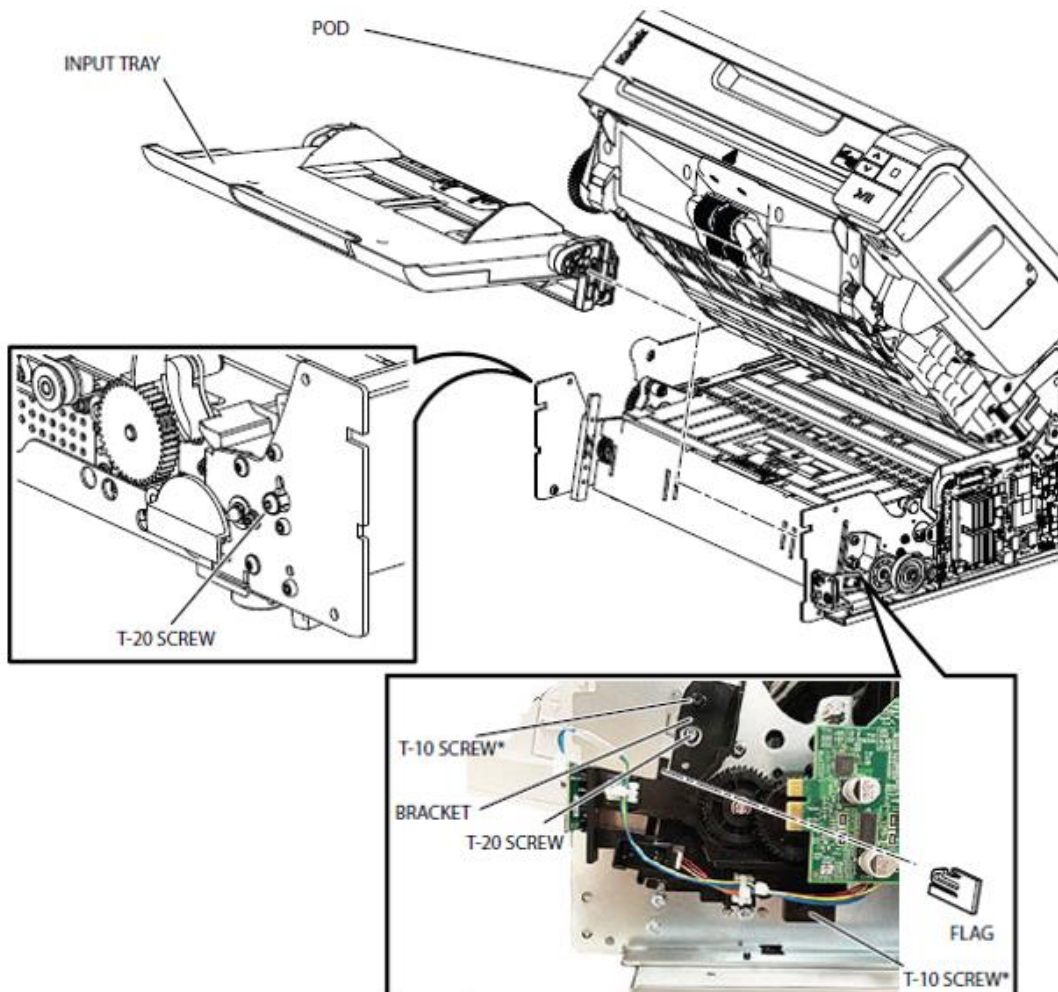

Remove the Bottom Cover

[1] Set the SCANNER on its back.

[2] Remove:

- eight T-10 SCREWS with WASHERS (circled in red)
- BOTTOM COVER

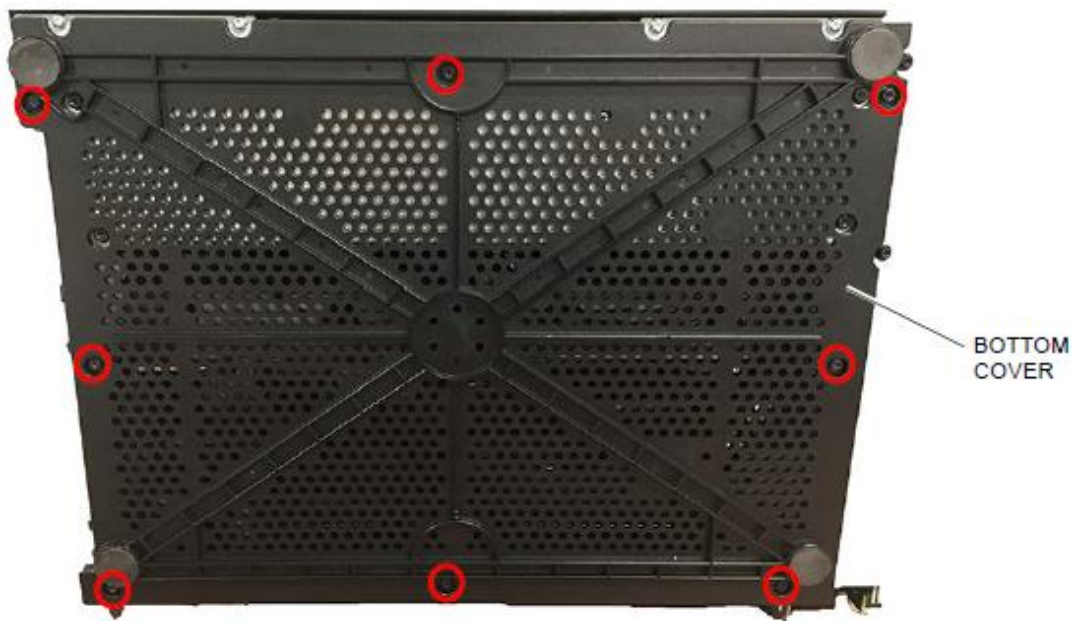

Remove the Operator Control Panel Assembly (OCP)

[1] Move and hold the HANDLE toward the front of the SCANNER.

[2] Insert a TOOL "A" in hole "A."

[3] Release the HANDLE.

[4] Insert and hold a TOOL "B" in hole "B." This releases the TAB on the OCP TOP COVER.

[5] Move the OCP TOP COVER toward the back of the SCANNER until it releases.

Note: Important - It may take extra force to remove the TOP COVER.

[6] Remove the OCP TOP COVER.

[7] Remove the TOOLS.

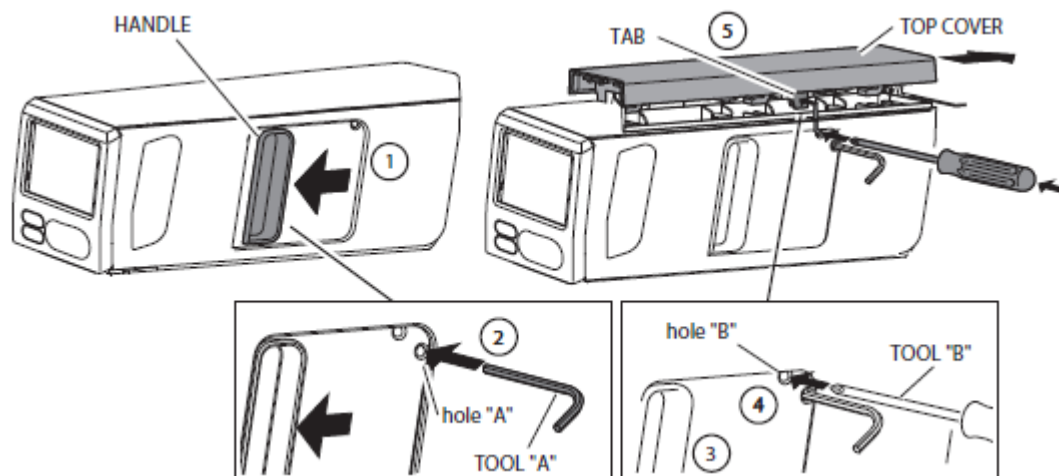

[8] Open the POD.

[9] From the bottom of the OCP AY, remove the two T-10 SCREWS - silver.

[10] Remove the OCP COVER (right).



[11] Move the POD downward but do not fully close it.

[12] Move the CLIP on the RIBBON CONNECTOR up.

[13] Remove the RIBBON CABLE.

[14] Remove:

- two T-10 SCREWS - silver
- OCP ASSY

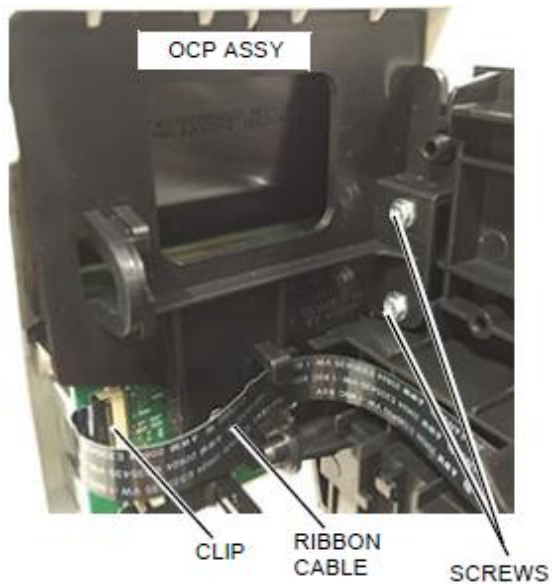

[15] Are you removing the OCP ASSY as a prerequisite for removing the INTEGRATED FLATBED SCANNER?

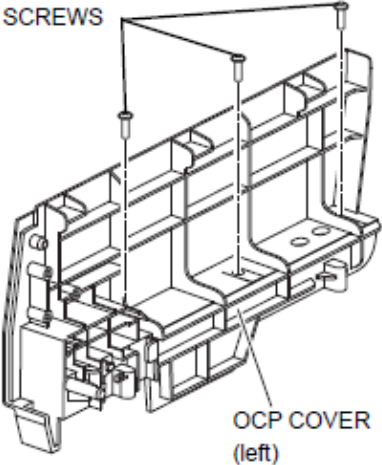
If	Then
Yes	 <p>Remove:</p> <ul style="list-style-type: none"> • three SCREWS • OCP COVER (left)
No	No further action is required.

Remove the Upper CIS Module

[1] Remove two T-10 SCREWS (silver).

Note: Important - Do not remove or loosen any other SCREWS. Removing or loosening SCREWS on the FLEXURES can introduce misalignment when the replacement CIS MODULE is installed.

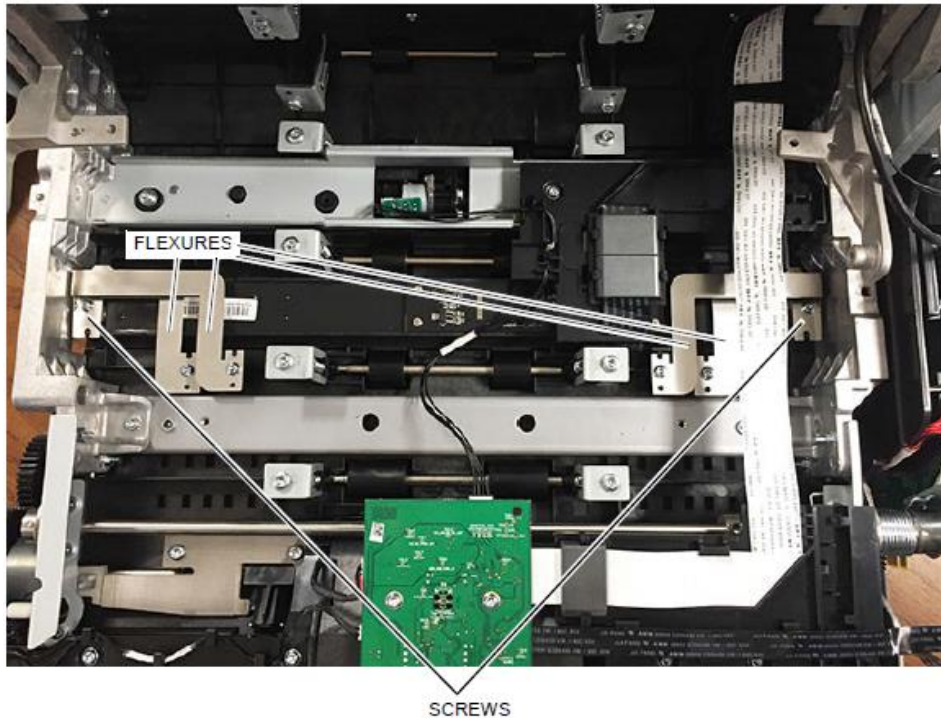

[2] Move the TAB up to release the CABLE.

[3] Disconnect the CABLE.

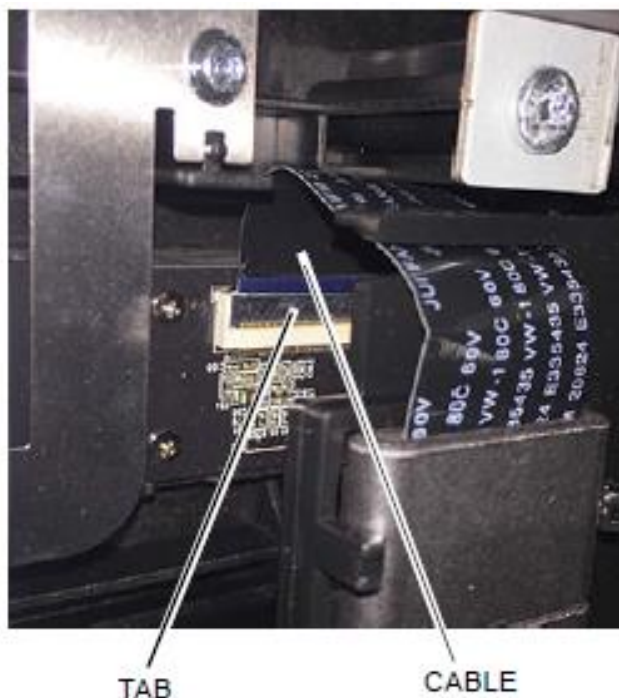

[4] Open the POD.

[5] Remove the UPPER CIS MODULE.



Remove the Upper Background Assembly

[1] Disconnect the CABLE from the connector on the UPPER CIS MODULE.

Note: The connector is below the CABLE HOLDER.

[2] Remove two T-10 SCREWS - silver.

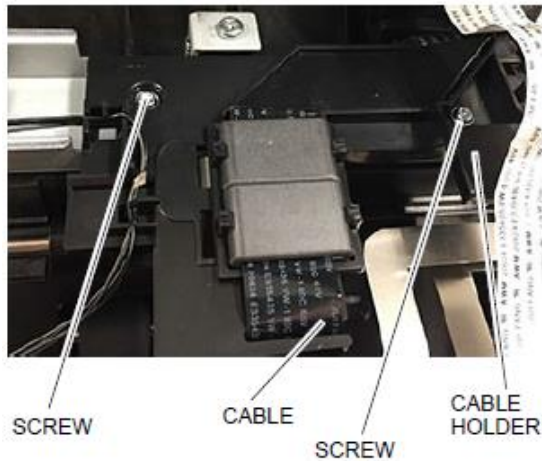

[3] Move the CABLE HOLDER so you can access the second SCREW in step 4.

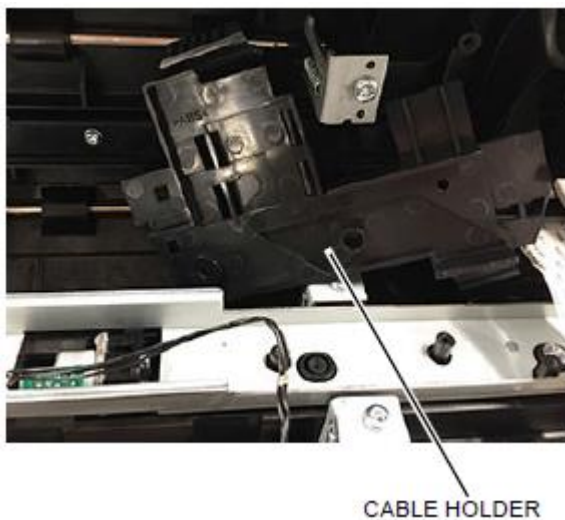

[4] Remove two T-10 SCREWS with WASHERS - silver.

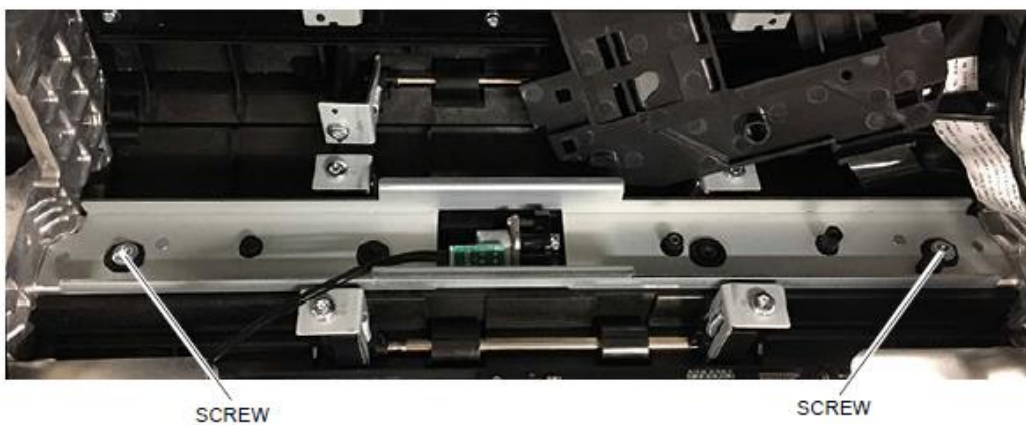

[5] Open the POD.

[6] Disconnect the MOTOR HARNESS.

[7] Remove the UPPER BACKGROUND ASSY.

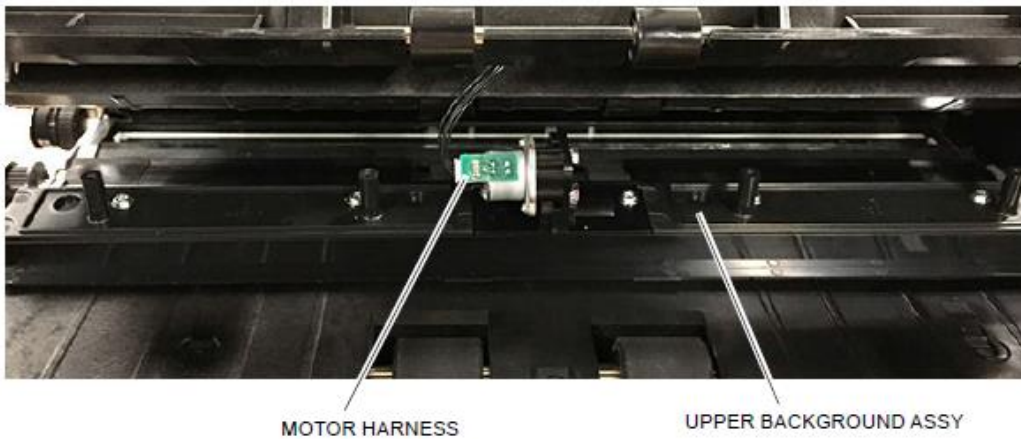

Remove the Lower CIS Module

- [1] Remove two SCREWS.
- [2] Move the TAB up to release the RIBBON CABLE.
- [3] Disconnect the RIBBON CABLE.
- [4] Turn the SCANNER over and open the POD.
- [5] Remove the LOWER CIS MODULE.

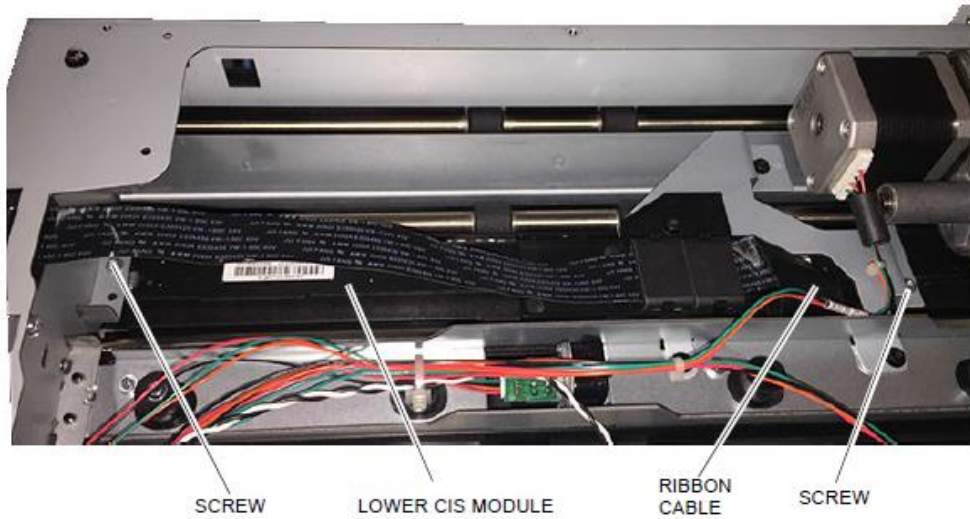

Remove the Lower Background Assembly

[1] Disconnect the BACKGROUND MOTOR HARNESS (Photo 1).

[2] Remove:

- two SCREWS (one SCREW not visible)
- COVER

[3] Remove the three SCREWS from the PLATE MOUNT, then move the PLATE out of the way.

[4] Carefully cut the TIE WRAP (Photo 1) that holds the HARNESSSES. Remove the TIE WRAP.

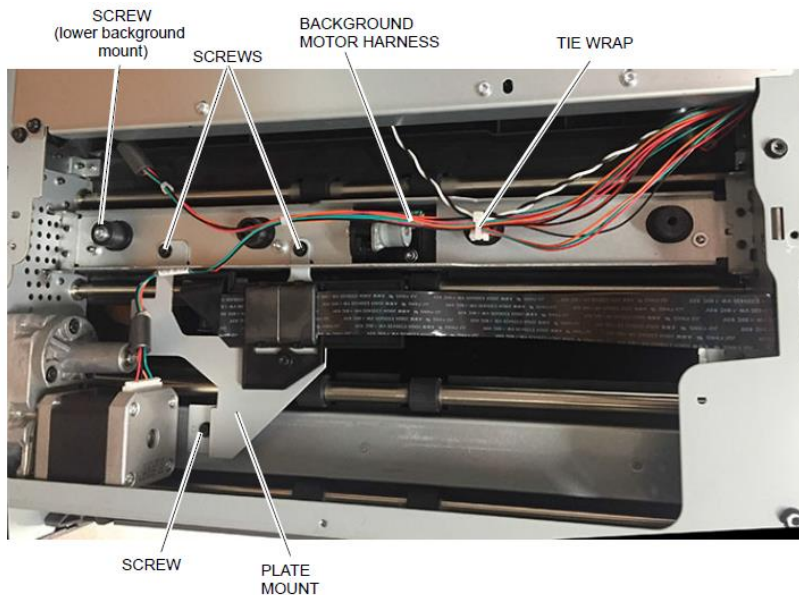

Photo 1

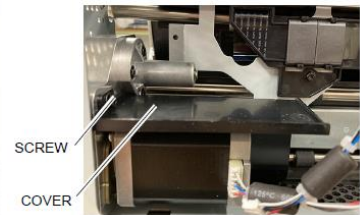
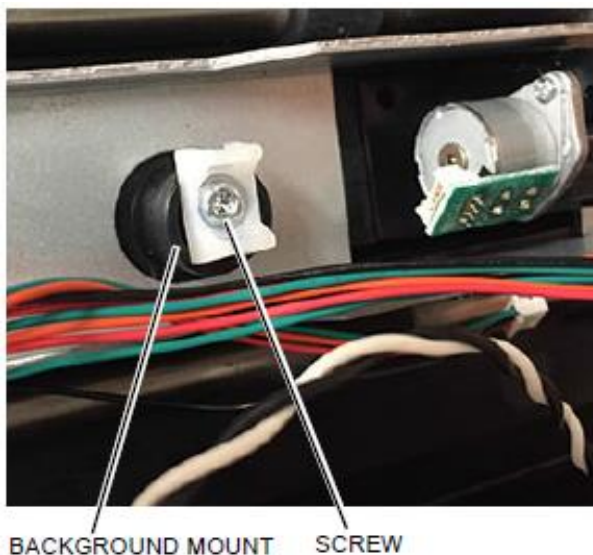

Photo 2

[5] Remove the SCREW from the TIE WRAP MOUNT / BACKGROUND MOUNT.



[6] Open the POD.

[7] Remove the LOWER BACKGROUND ASSY.

Remove the Feed Module

- [1] Open the POD.
- [2] Press and hold the LEVER to release the FEED MODULE.
- [3] Remove the FEED MODULE.

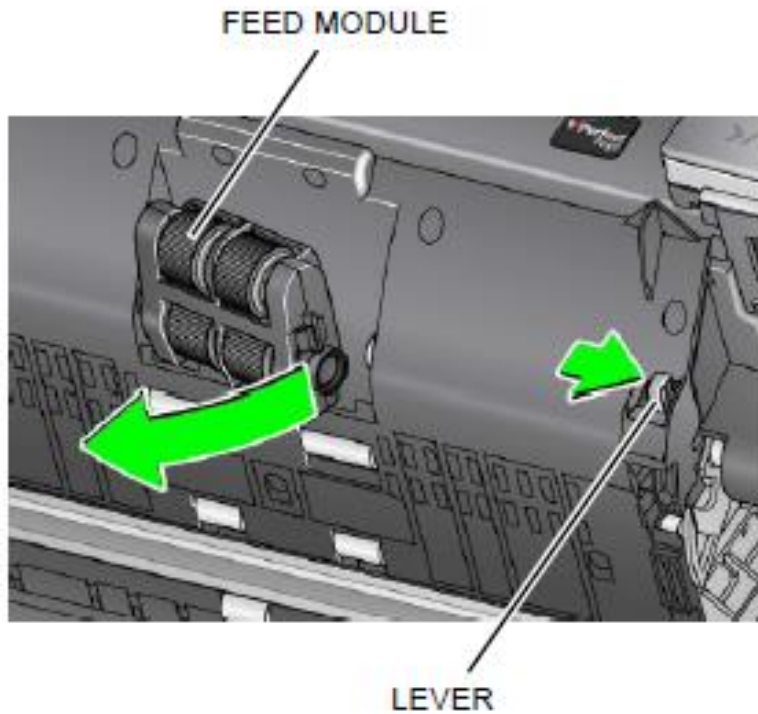

Remove Upper ADF Baffle

[1] Open the POD.

Note: All the following SCREWS have WASHERS.

[2] From the bottom of the UPPER ADF BAFFLE, remove:

- four SCREWS (top)
- one SCREW (left, short)
- two SCREWS (left)
- five SCREWS (short)
- one SCREW (right, short)
- two SCREWS (right)

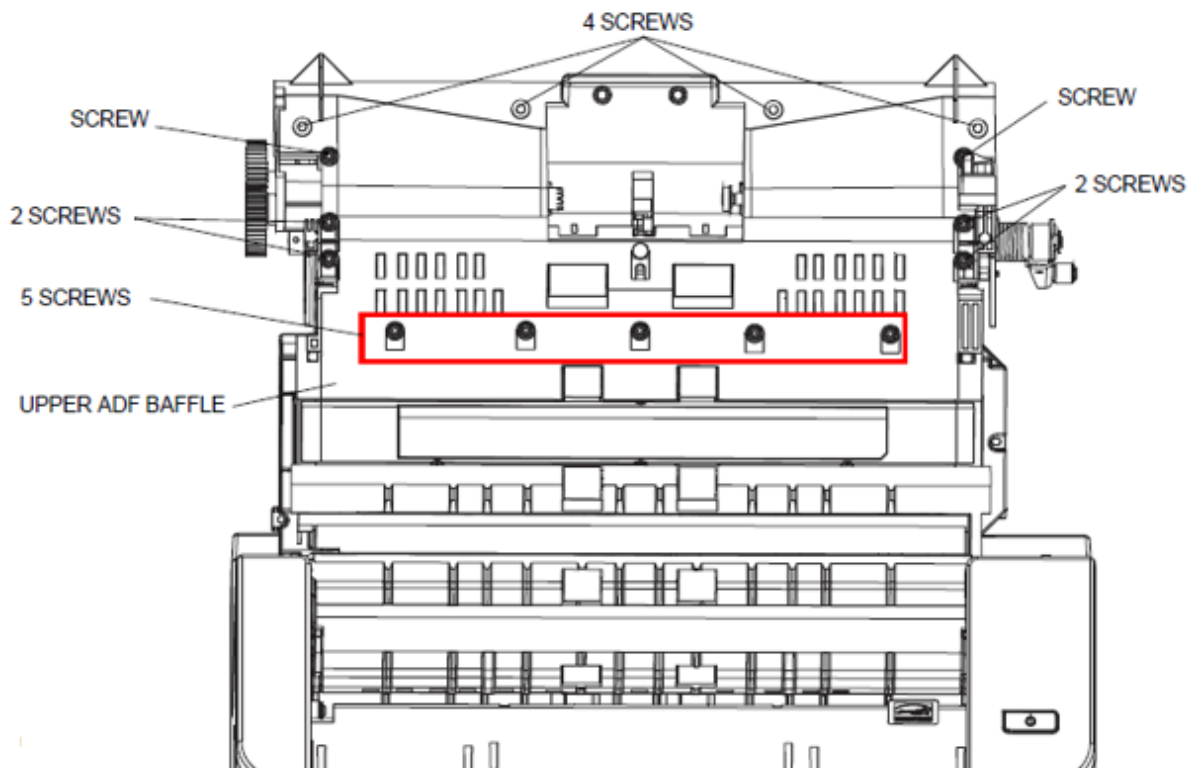

[3] Remove:

- four SCREWS (silver)
- three SCREWS (silver) from the SENSOR INTERFACE BOARD

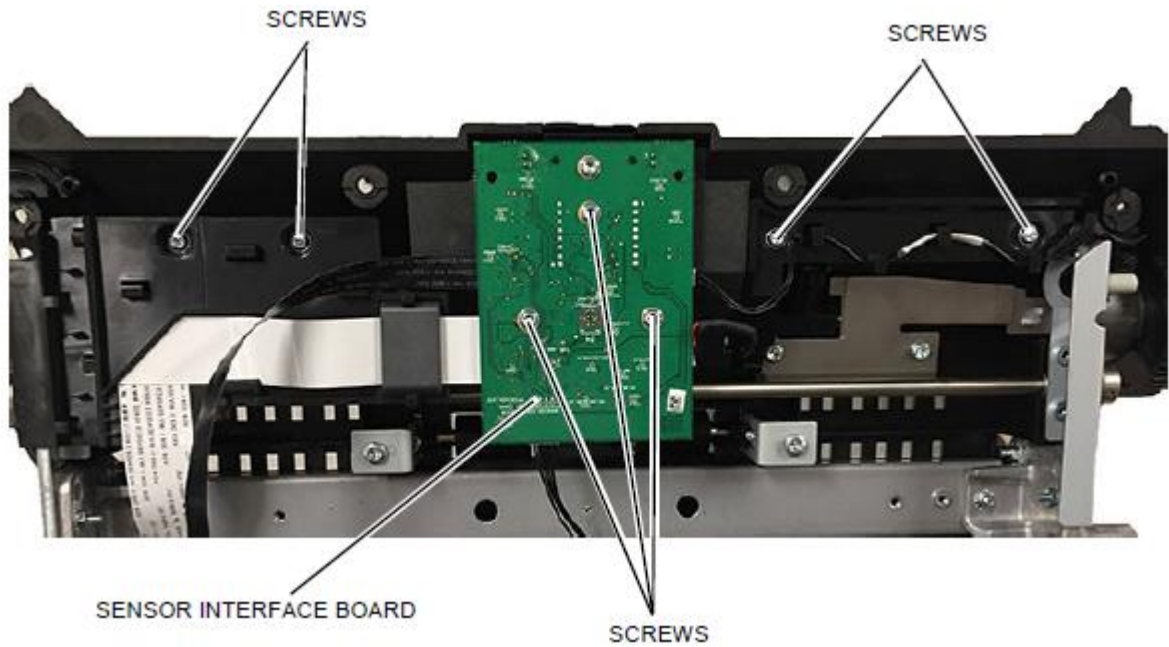

[4] Disconnect the five CABLES from the SENSOR INTERFACE BOARD.

Note: Important - There are three spacers under the SENSOR INTERFACE BOARD. Be sure to keep them in place when you remove the next two parts.

[5] Remove the:

- SENSOR INTERFACE BOARD
- UPPER ADF BAFFLE

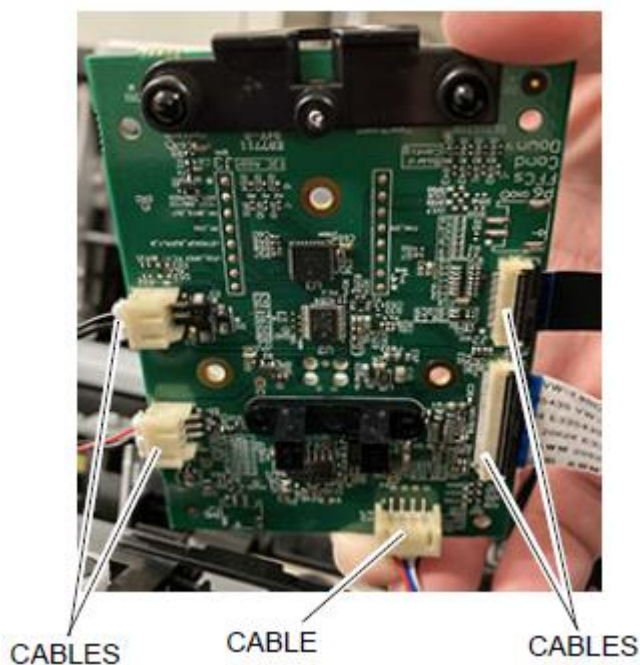

Remove the Sensor Interface Board

[1] Remove the three SCREWS from the SENSOR INTERFACE BOARD.

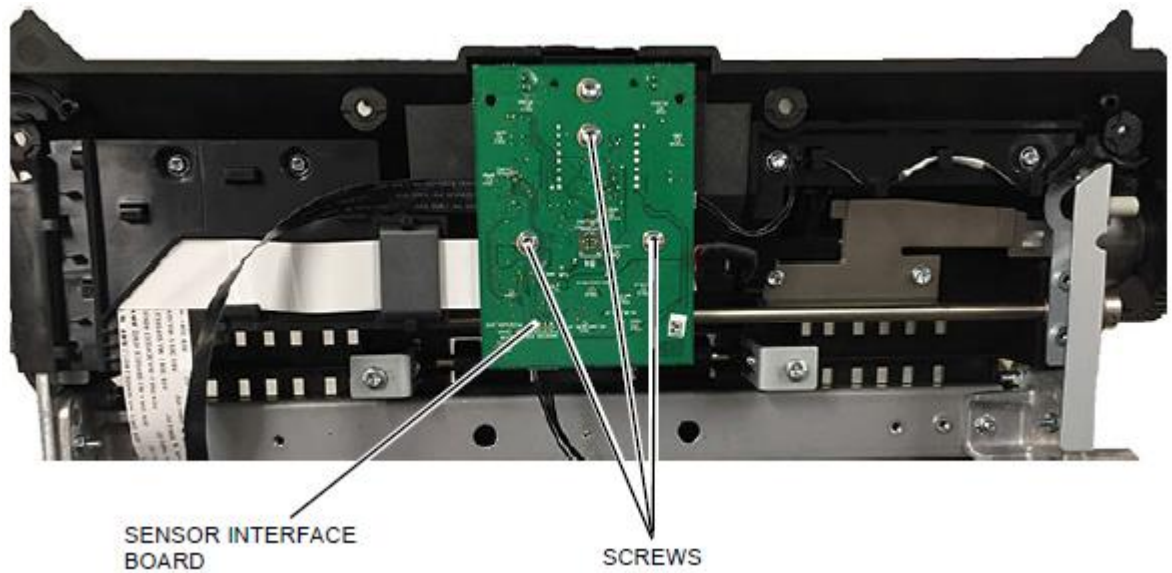

[2] Disconnect the five CABLES from the SENSOR INTERFACEBOARD.

Note: Important - There are three spacers under the SENSOR INTERFACE BOARD. Be sure to keep them in place when you remove the next two parts.

[3] Remove the SENSOR INTERFACE BOARD.

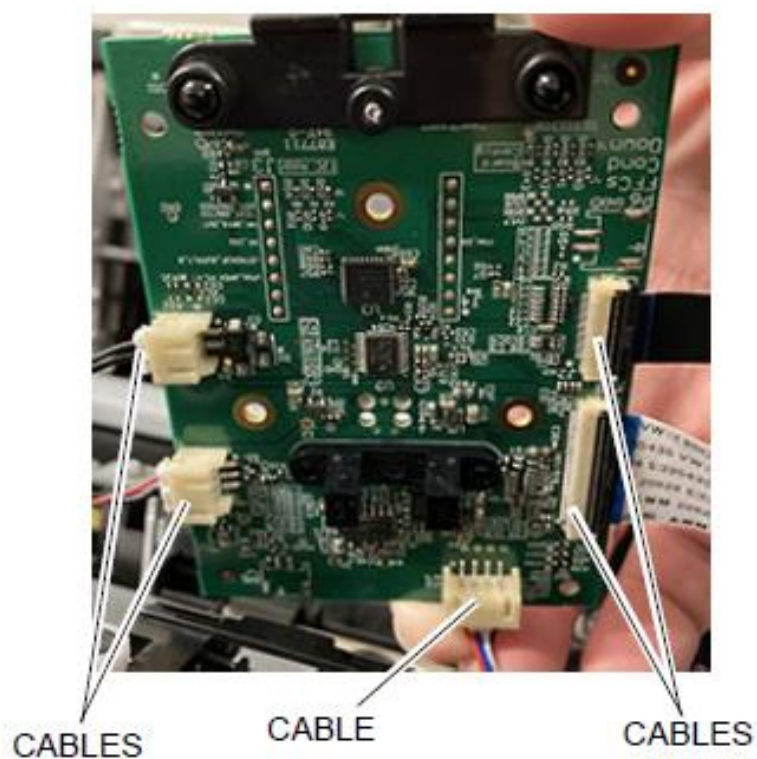

Remove the Controller Board

[1] Open the POD (as needed).

[2] Disconnect:

- a. MAIN HARNESS
- b. SENSOR HARNESS
- c. CIS MODULE CABLE (POD) – flip tab to release
- d. CIS MODULE CABLE (Base) – flip tab to release
- e. SENSOR BOARD HARNESS – flip tab to release
- f. SENSOR HARNESS
- g. Internal USB CABLE - "f" models only

[3] Remove four T-10 SCREWS (silver). Two SCREWS have coarse threads, and two SCREWS have fine threads.

Note: ESD - Possible damage from electrostatic discharge.

[4] Remove the CONTROLLER BOARD.

[5] Remove the BATTERY.

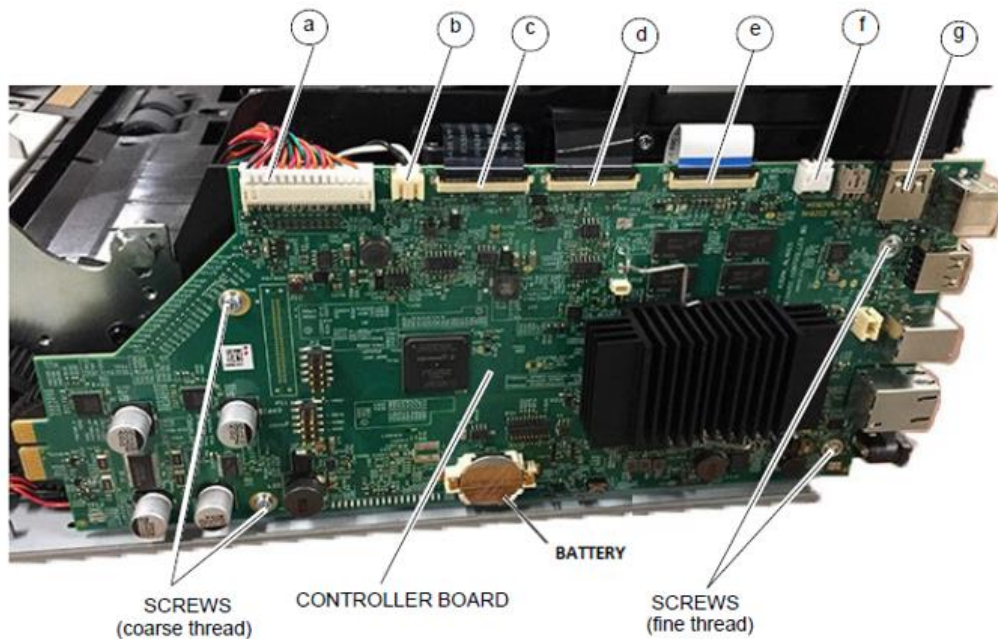

Remove the Diverter Assembly

- [1] On the right side, remove:
- two T-10 SCREWS with WASHERS (black)
 - CABLE HOLDER

- [2] Move the CABLE HOLDER and CABLES out of the way.

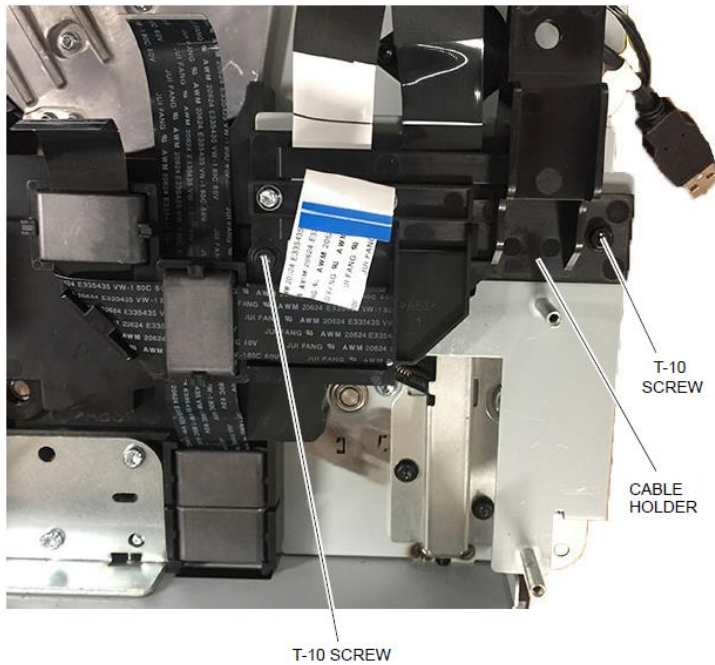

- [3] On the right side, remove:
- three T-10 SCREWS with WASHERS – black
 - SUPPORT BRACKET

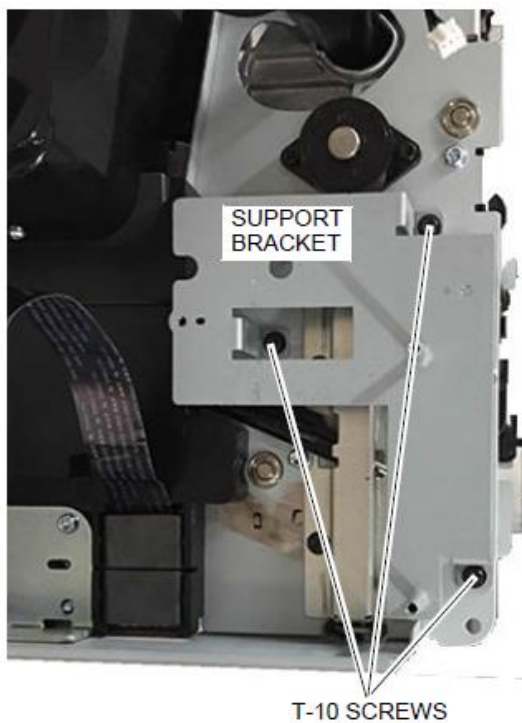

[4] Remove:

- four T-10 SCREWS with WASHERS (black)
- T-10 SCREW (inside) (silver)
- SHOCK ("plunger") and COVER

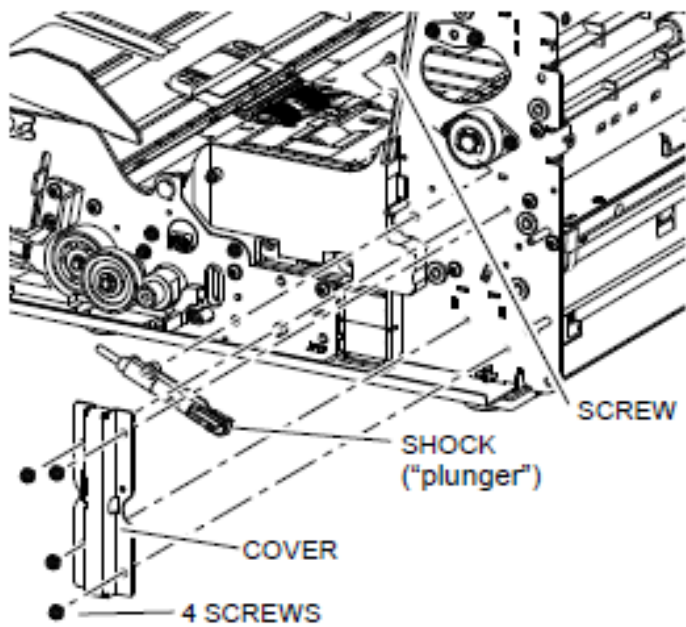

[5] On the left side, remove:

- two T-10 SCREWS with WASHERS (black)
- COVER

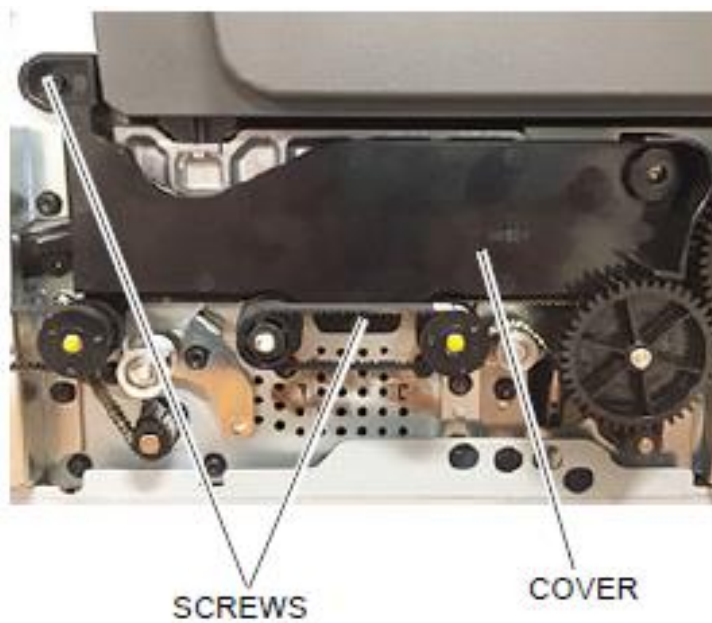

- [6] On the left side, remove:
- four T-10 SCREWS with WASHERS (black)
 - T-10 SCREW (inside) (silver)
 - SHOCK ("plunger") and COVER

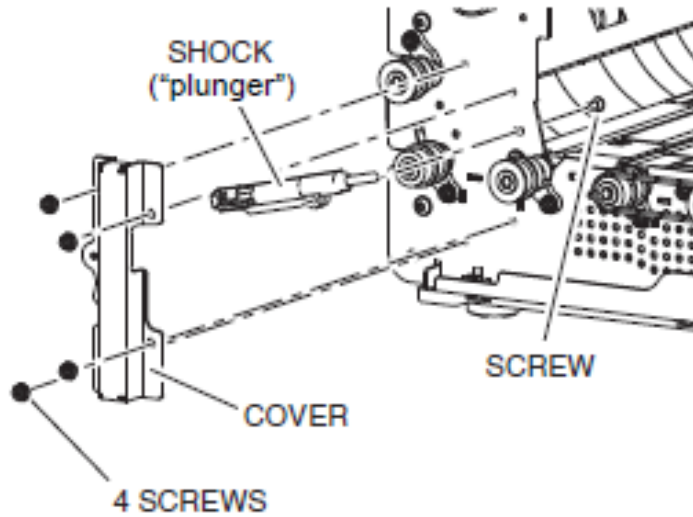

- [7] Remove two SCREWS (silver) from the DIVERTER ASSY (at the sides).

Note: The SCREW on the left side of SCANNER is not shown.



[8] Remove three T-10 SCREWS (silver).

Note: Important - Verify that the LEVER is in the down position.

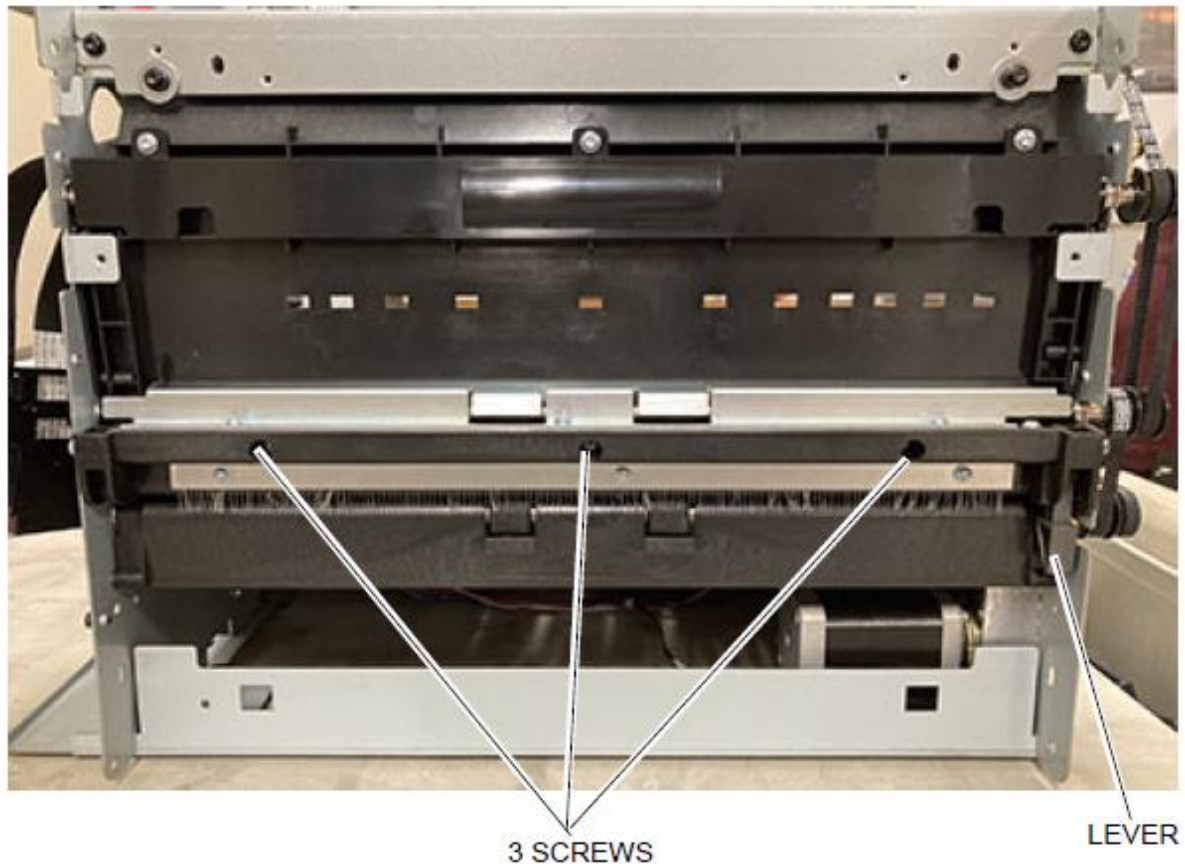

[9] From the inside of the SCANNER, apply firm pressure at the bottom of the DIVERTER ASSY so that it clears the LIP at the bottom of the BAFFLE, then remove the DIVERTER ASSY from the back of the SCANNER.

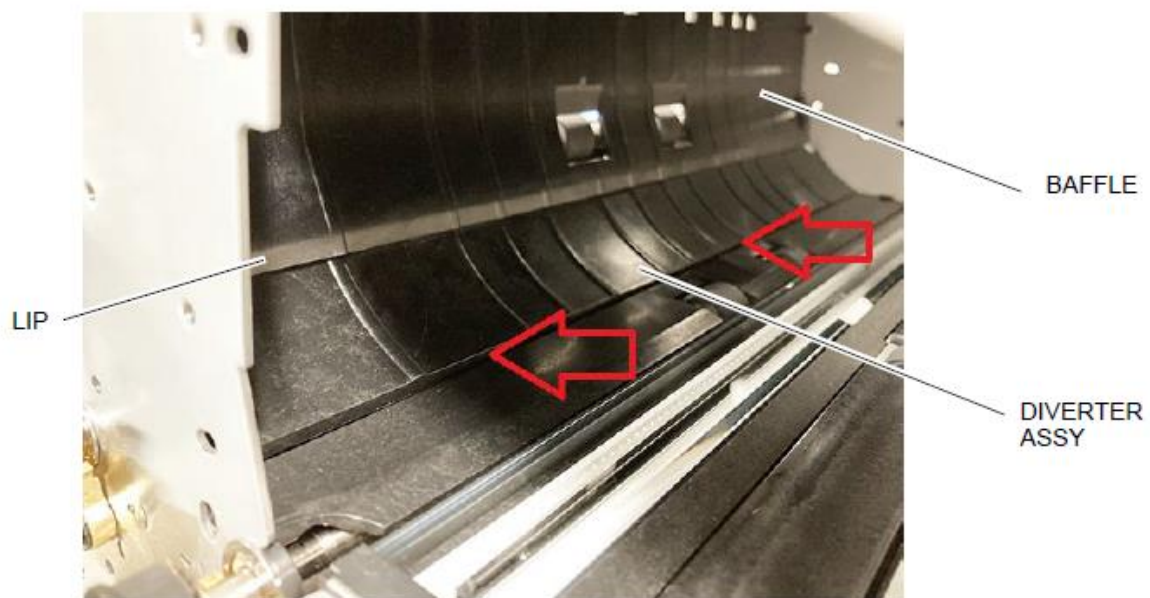

Remove the Takeaway Drive Shaft

- [1] From the bottom of the SCANNER, remove:
- four T-10 SCREWS "A" (with washers) - black
 - six T-10 SCREWS "B" – silver
 - CHANNEL - frame base

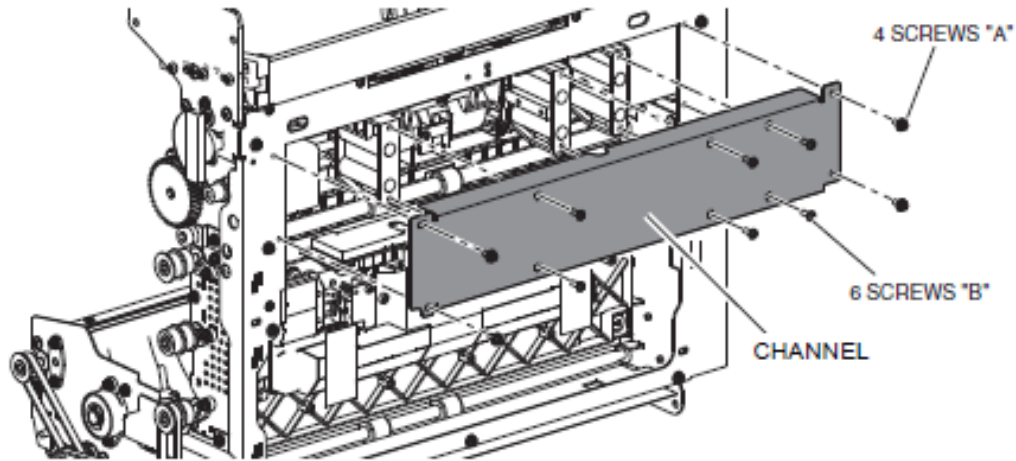

- [2] From the left side, remove:
- two SCREWS
 - IDLER AY
 - two BELTS

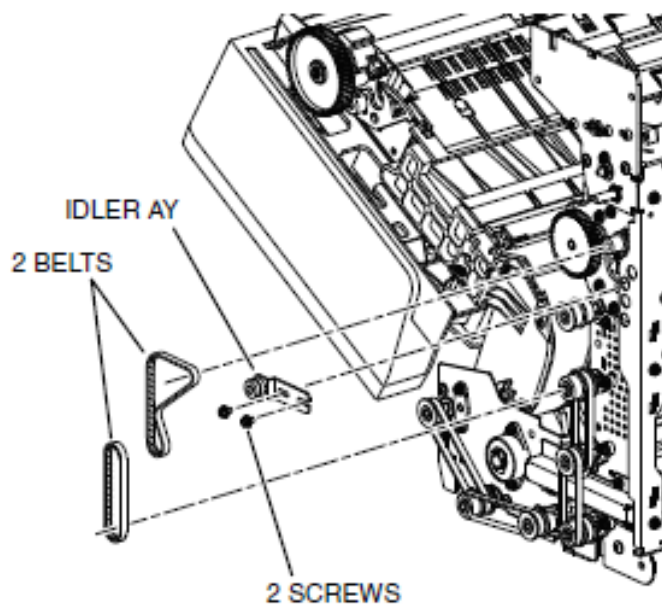

[3] Disconnect the HARNESS from the MOTOR.

[4] Remove:

- two T-10 SCREWS with WASHERS - black
- MOTOR (top)

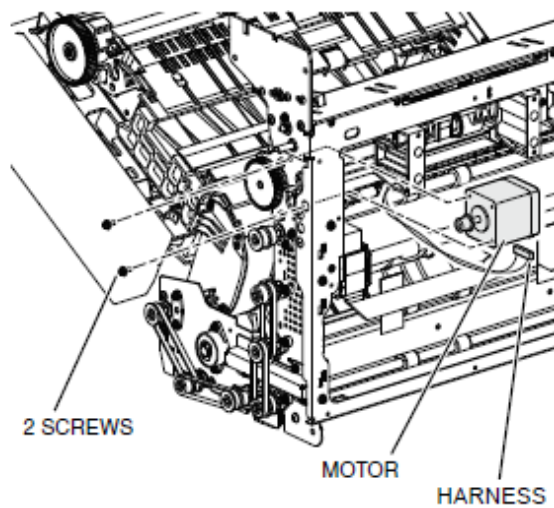

[5] Remove:

- two T-10 SCREWS - silver (not shown in photo)
- SUPPORT - ADF, left
- two SCREWS T-10 SCREWS - silver (not shown in photo)
- SUPPORT - ADF, center

Note: It is not necessary to remove the SUPPORT - ADF, right.

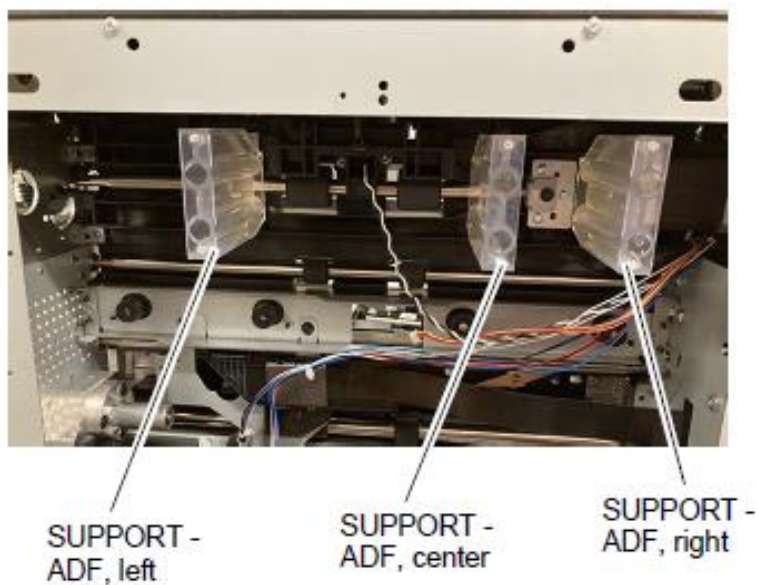

[6] Remove:

- two T-10 SCREWS (silver).
- UDDS SENSOR and BRACKET
- T-10 SCREW with WASHER - black
- CLAMP BEARING

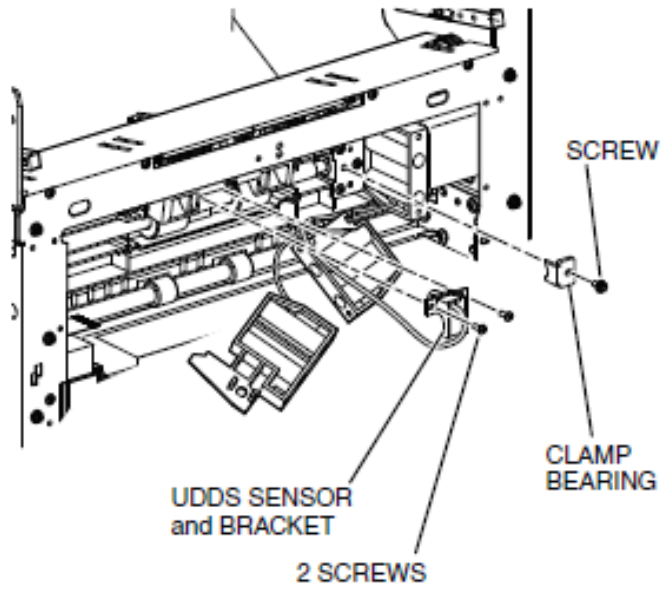

[7] Remove the TAKEAWAY SHAFT.

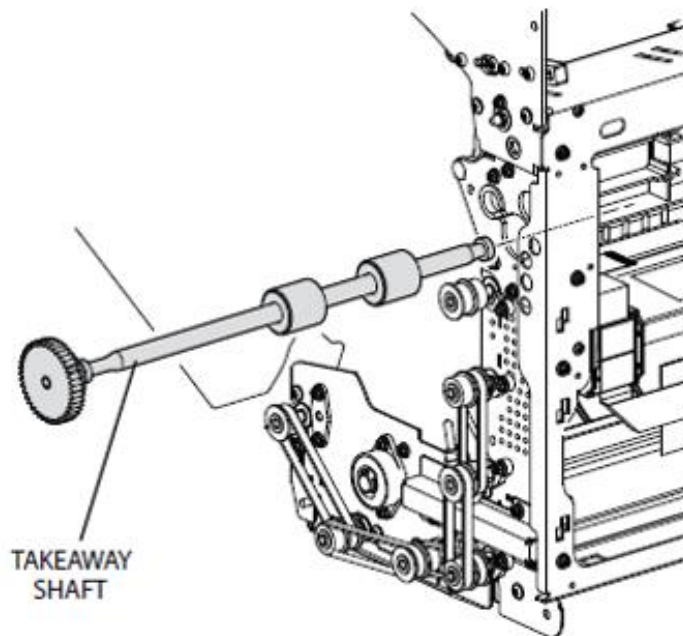

Remove Drive Shafts #1 and #2

- [1] From the bottom of the SCANNER, remove:
- four T-10 SCREWS "A" (with washers) - black
 - six T-10 SCREWS "B" - silver
 - CHANNEL - frame base

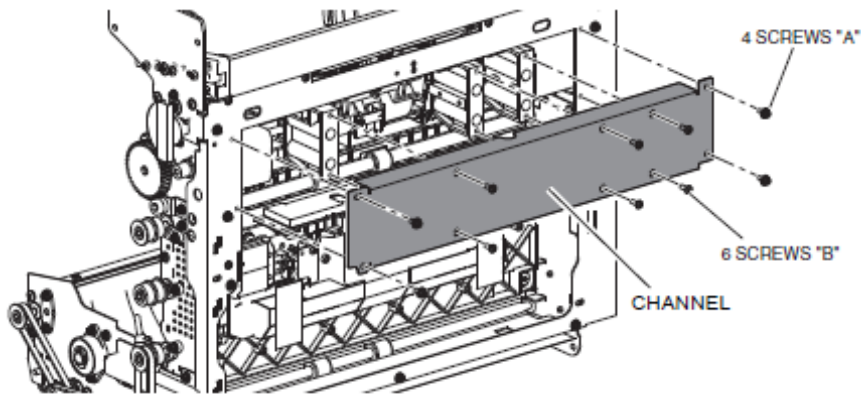

- [2] Loosen the T-10 SCREW (black) at the IDLER ASSY.

- [3] Remove two BELTS.

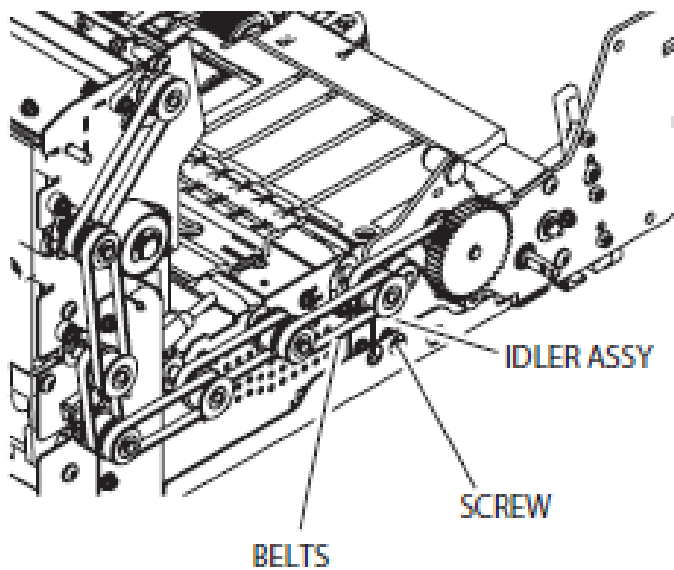

- [4] With the POD open, remove:

- T-10 SCREW - black
- PANEL

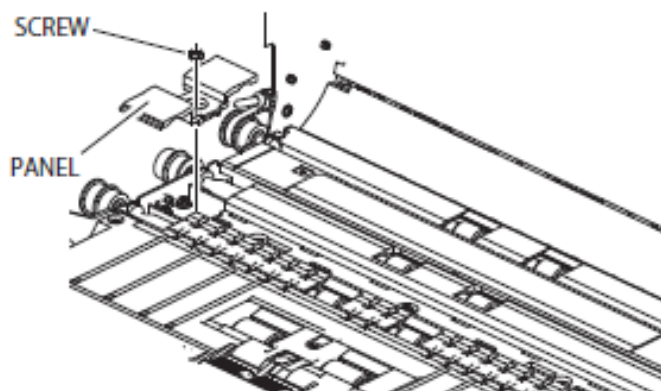

[5] Loosen the SCREW for the RETAINER.

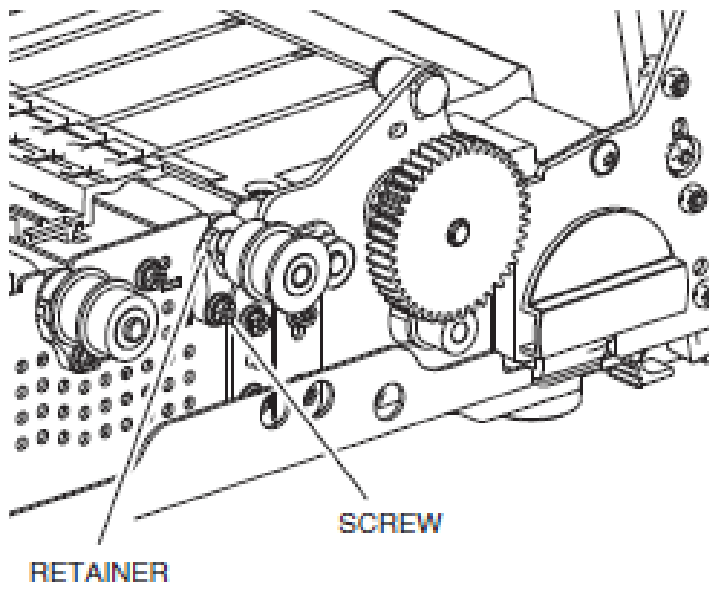

[6] Remove DRIVE SHAFT #1.

[7] Repeat steps 5 and 6 to remove DRIVE SHAFT #2.

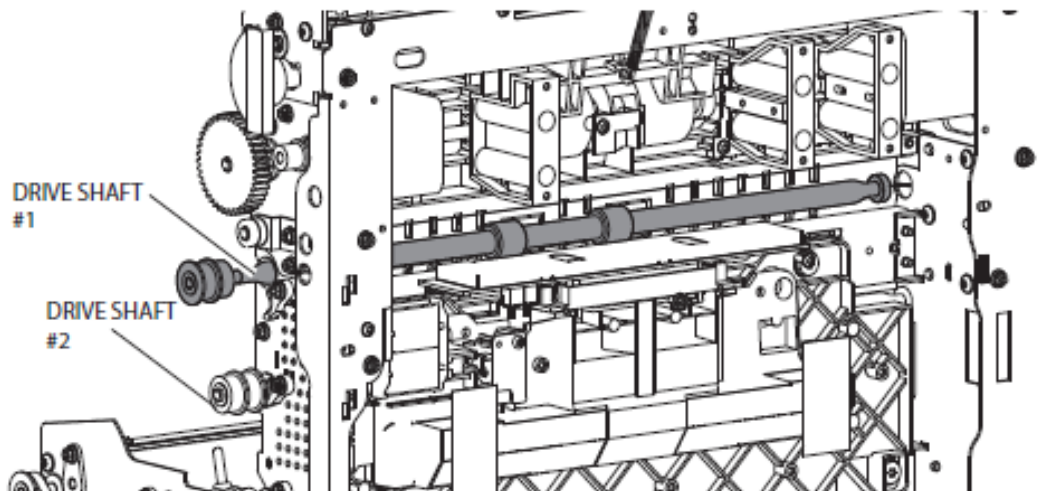

Remove Drive Shaft #3

[1] Remove

- T-10 SCREW - black
- IDLER ASSY
- BELT

[2] Loosen the SCREW on the BEARING RETAINER and move the RETAINER out of the way.

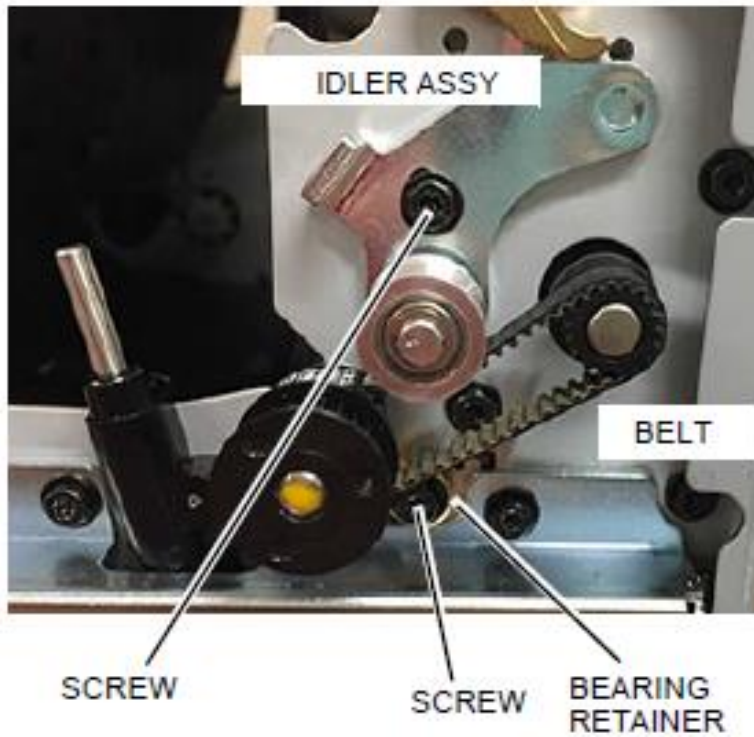

[3] Loosen the SHAFT from the BEARING end (not shown).

[4] To remove the DRIVE SHAFT #3, angle the end of the SHAFT to release it from its position.

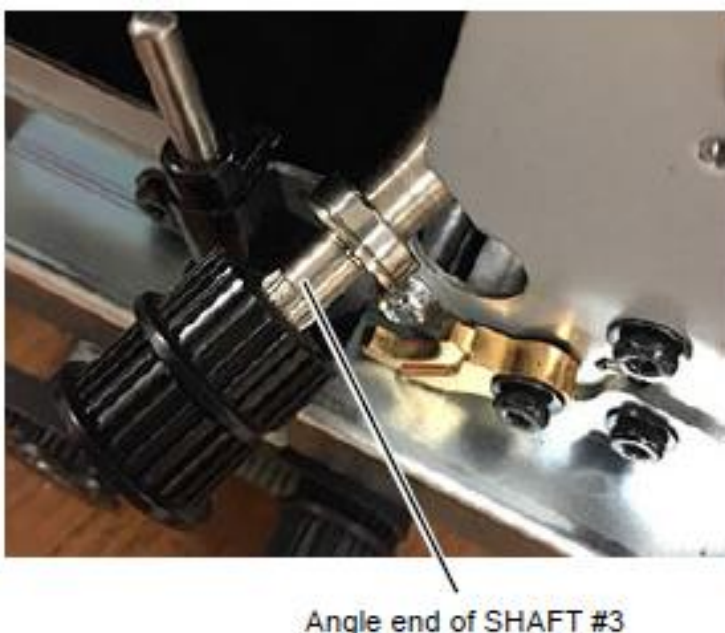

Remove Drive Shaft #4

- [1] From the back of the SCANNER, remove:
- four T-20 SCREWS - silver
 - COVER

- [2] Remove three 7/32-in. NUTS.

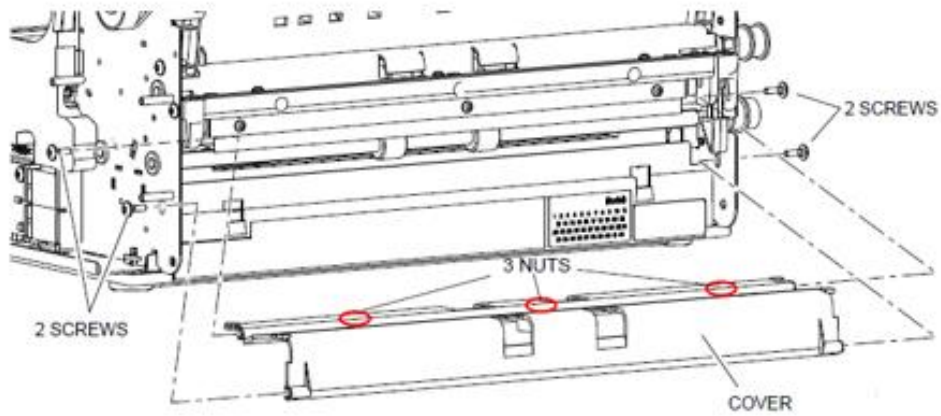

- [3] Remove the BELT from the GEAR/SHAFT.

- [4] Loosen the SCREW on the RETAINER and move the RETAINER out of the way.

- [5] Remove DRIVE SHAFT #4.

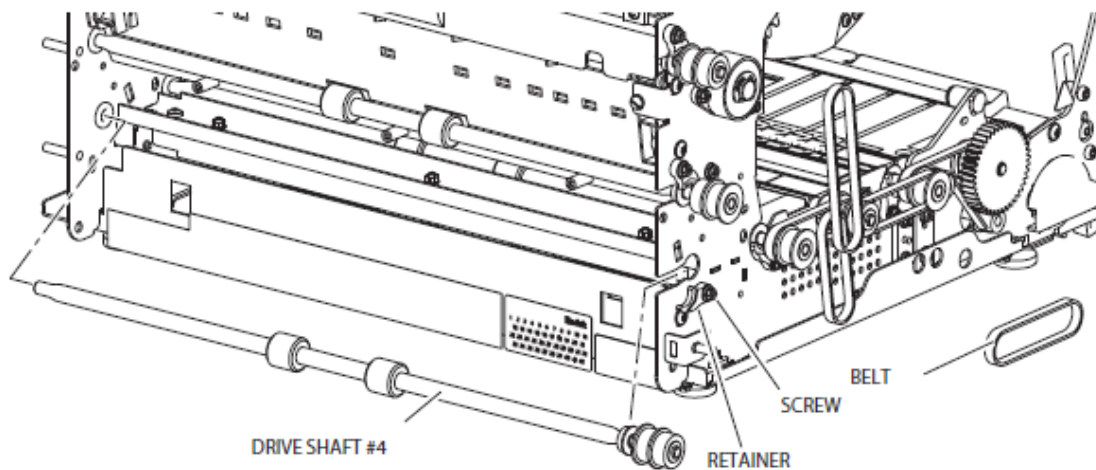

Remove Drive Shaft #5

- [1] Remove:
- three SCREWS
 - BRACKET

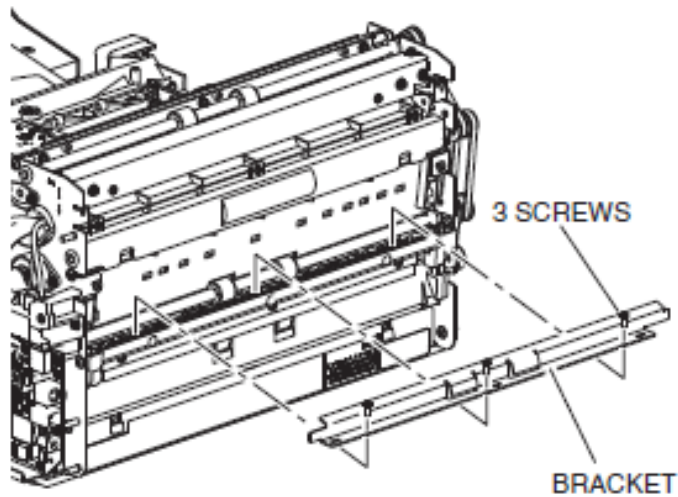

[2] Remove the three BELTS.

[3] Loosen the SCREW for the RETAINER and move the RETAINER out of the way.

[4] Remove DRIVE SHAFT #5.

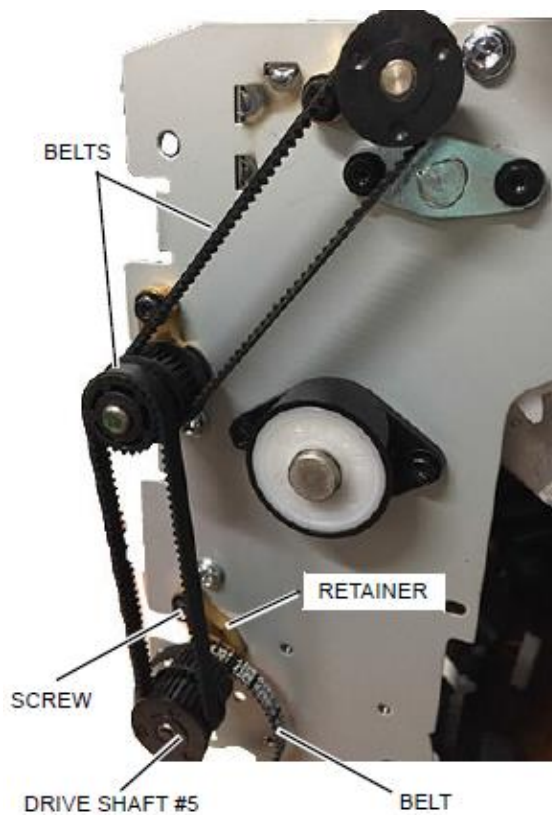

Remove Drive Shaft #6

[1] Remove:

- three SCREWS
- COVER
- BELTS

[2] Loosen the SCREW for the RETAINER - not shown in the graphic.

[3] Remove DRIVE SHAFT #6.

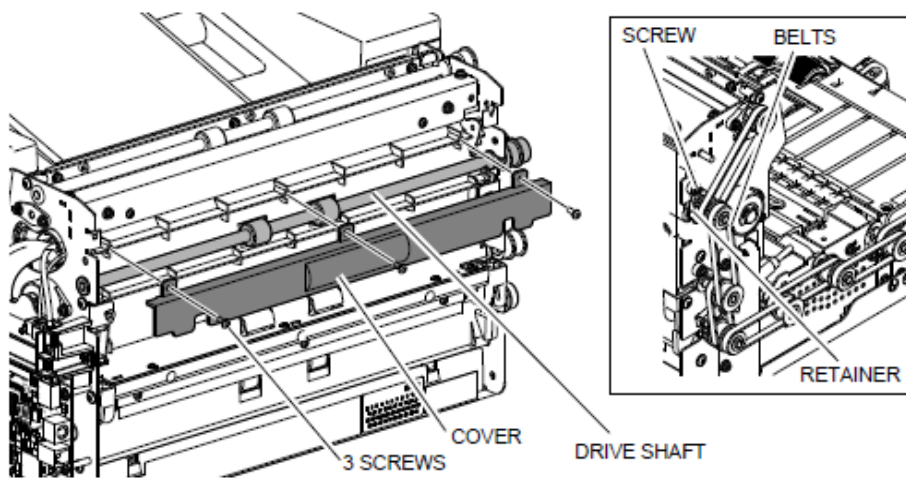

Remove the Exit Drive Shaft

- [1] Loosen the SCREW for the RETAINER and move the RETAINER out of the way.
- [2] Move the BELT from the GEAR.
- [3] Remove the EXIT DRIVE SHAFT.

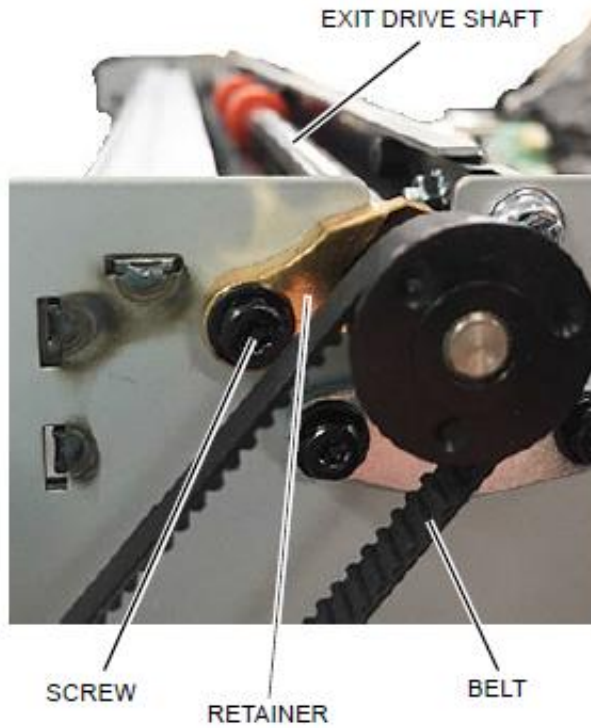

Remove NFR Shafts – Takeaway and #1 through #5

Note: See the location of the NFR SHAFTS below. The photo shows the SCANNER with the POD closed and the OUTPUT TRAY ASSY or INTEGRATED FLATBED SCANNER and BACKSTOP removed. (SHAFT No. 5 is installed behind the BACKSTOP [not shown].)

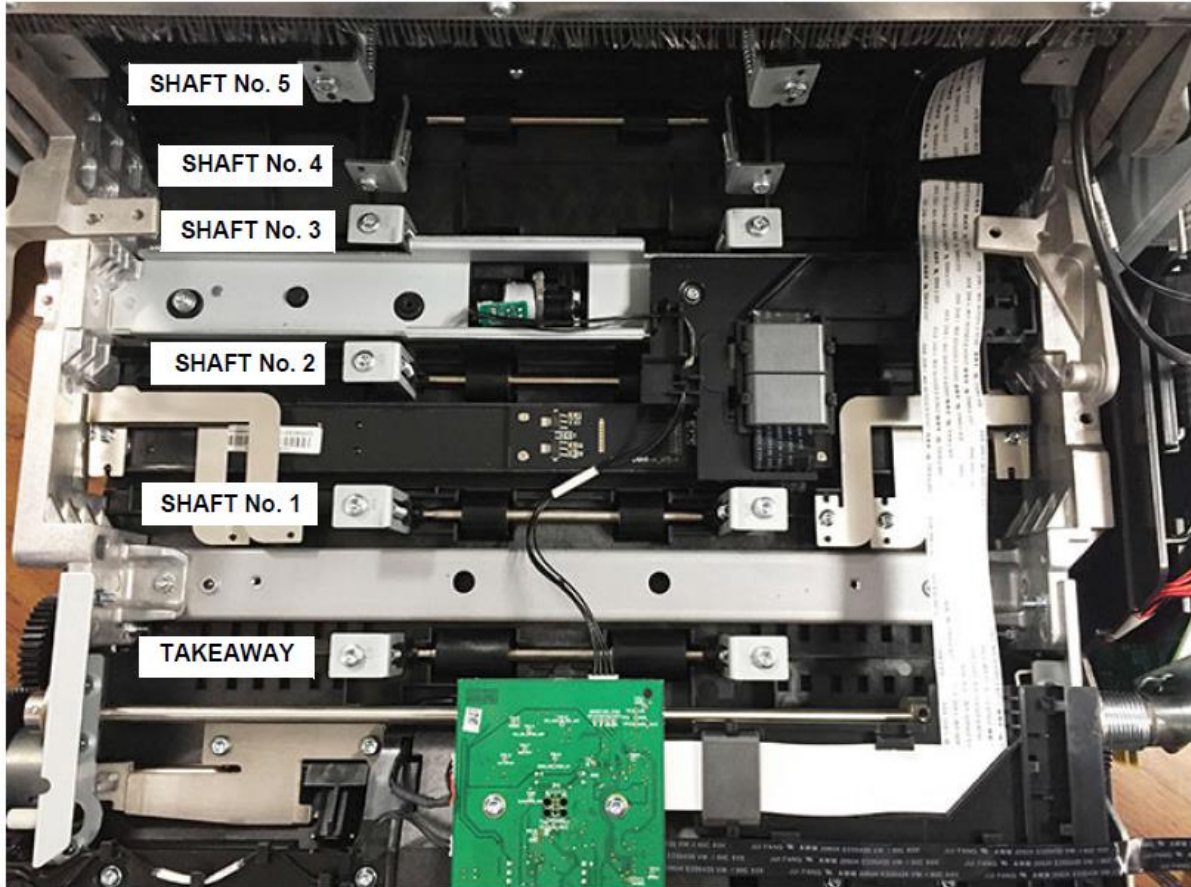

CAUTION: The SHAFT and NFRs are spring-loaded. Use care when you remove the SHAFT ASSY from the BACKSTOP.

[1] Which NFR SHAFT are you removing?

If	Then
<ul style="list-style-type: none"> • TAKEAWAY NFRSHAFT • NFR SHAFT #1, 3, or 4 	Continue with Step 2
NFR Shaft #2	<ol style="list-style-type: none"> Disconnect the CABLE for the UPPER CIS MODULE Remove two SCREWS from the CABLE HOLDER Move the CABLE HOLDER so you can access the second SCREW and BRACKET for this SHAFT Continue with step 2.
NFR Shaft #5	<ol style="list-style-type: none"> Remove: <ul style="list-style-type: none"> • five SCREWS • BACKSTOP Continue with step 2.

[2] Remove:

- two SCREWS
- two BRACKETS (silver)
- two SPRINGS; the SPRINGS may stay attached to the BRACKETS when you remove the BRACKETS

[3] Remove the SHAFT ASSY.



Note: The BUSHING on the left side of the SHAFT is held in place by a RETAINER CLIP. The BUSHING on the right side is not retained.

Remove the Exit NFR Shaft – Backstop

[1] Remove:

- two T-10 SCREWS - silver
- three T-20 SCREWS - silver
- BACKSTOP

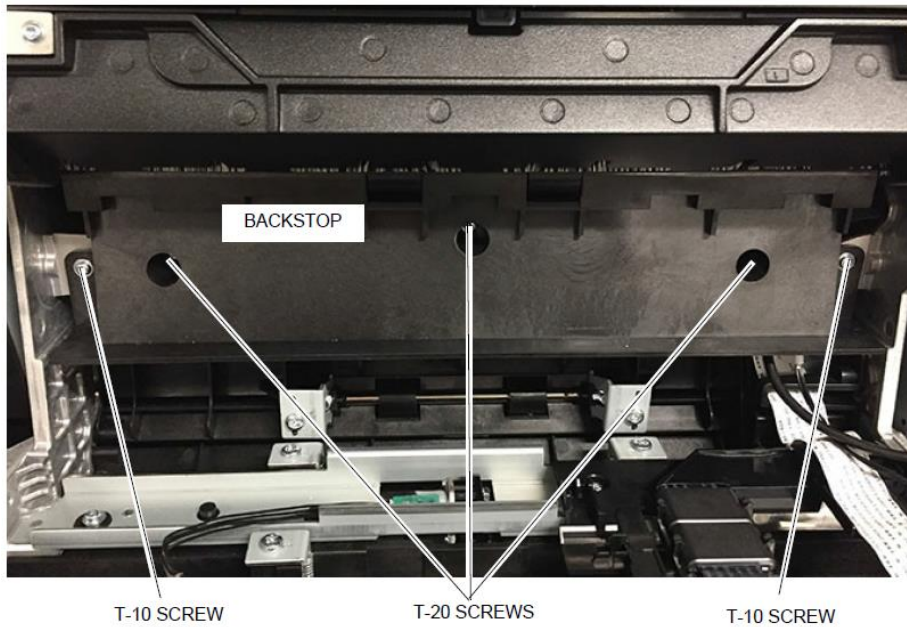

CAUTION: The SHAFT and NFRs are spring-loaded. Use care when you remove the SHAFT ASSY from the BACKSTOP.

[2] Remove:

- SCREW
- STOP
- SHAFT (includes the NFR ROLLERS)
- SPRINGS

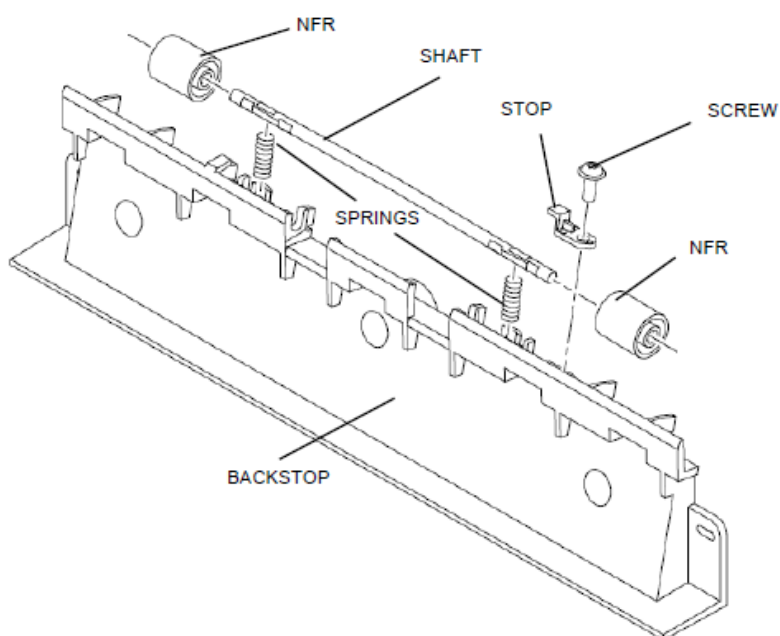

Remove the Exit NFR Shaft – Diverter Assy



CAUTION: The SHAFT and NFRs are spring-loaded. Use care when you remove the SHAFT ASSY from the DIVERTER ASSY,

- [1] Remove one SCREW and SPRING HOLDER.
- [2] Hold the SHAFT, then remove the other SCREW and SPRING HOLDER.
- [3] Remove the NFR SHAFT ASSY.

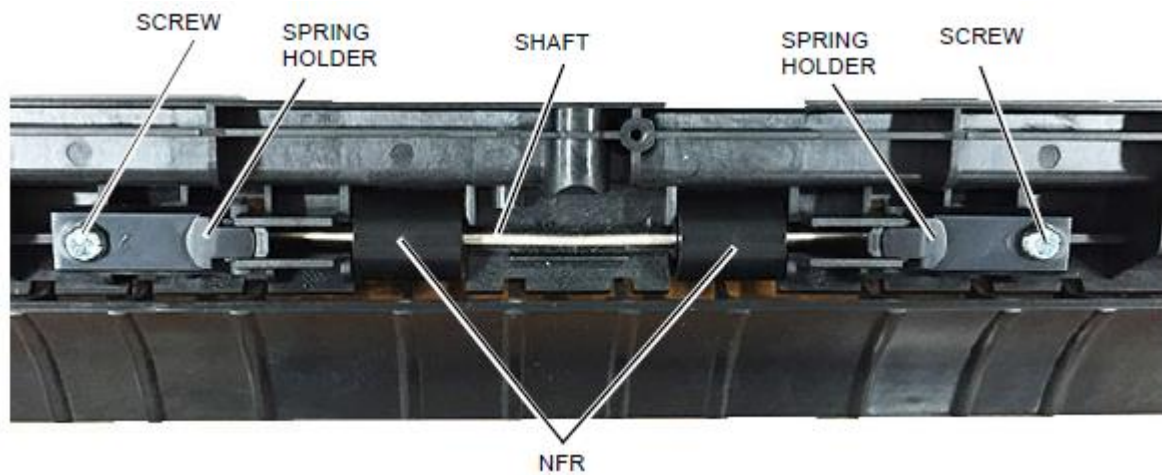

EOL Strategy

The product EOL strategy will be based on market needs, regulations, financial impact, etc. For example, the WEEE Directive in the European Union requires that a collection and treatment infrastructure is in place to manage our products at end-of-life. This obligation will be met through membership in a variety of governmental and industry-led collection schemes, as well as Kodak Alaris initiated strategies developed specifically for Kodak Alaris products. Strategies such as re-use, re-conditioning, strip and salvage, responsible disposal, etc. can vary by region and change with time.

Regulatory Requirements

The hazardous materials that are contained within this product need to be handled in compliance with the local requirements when discarded by the final user and sent for end-of-life treatment.

For recycler processes, substances, preparations, and components may be removed manually, mechanically, or chemically, metallurgically with the result that hazardous substances, preparation, components are contained in an identifiable waste stream or identifiable part of a waste stream at the end of the treatment process.

- Batteries must be processed by vendors capable of and experienced in recovering and recycling lead, acid, cadmium, nickel, copper, zinc, and other metals that may be present in batteries.
- LCDs (liquid crystal displays) must be processed by vendors capable of and experienced in recovering mercury in backlights.
- PC (printed circuit) boards must be processed by a smelter (or other thermal process) capable of and experienced in recovering precious metals (gold and so forth) and heavy metals (lead and so forth) for reuse or by a chemical recovery process. Circuit components may be extracted for reuse prior to smelting.
- Plastics should be recycled for use in new products, components, and materials, as substitutes for other raw materials, or recycled in another beneficial manner. When recycling is not economically practical, plastics should be processed for energy recovery at a facility that is designed to control and monitor emissions from the process. See section 14.9 for related information.
- Printing supplies collected as part of hardware recycling (for example, a print cartridge present in a printer at the time of its collection): Original HP printer cartridges must be processed using the HP Inkjet cartridge and LaserJet toner cartridge return and recycling programs in countries where HP programs are available. All other print supplies must be recycled or disposed of in an environmentally responsible manner compliant with applicable laws and regulations.
- Metal (other than in PC boards): Acceptable processing includes liberation of metal items (manually or mechanically), volume reduction for transport (shredding, baling, and so forth), and refining by smelters or foundries (or similar) for the purpose of preparing the metal for reuse. To maximize recycling rates, sending whole products to a smelter is not authorized without approval from HP and demonstration that the smelter is capable of capturing all of the following for reuse: copper, precious metals (such as gold and silver); steel and aluminum; and, for CRT devices, lead.
- Incineration: If lead-bearing electronic components (such as circuit boards), batteries, polyvinyl chloride (PVC) plastics, mercury lamps, or any material classified as hazardous waste under applicable regulations are disposed of by incineration, the incinerator must meet 99.99% destruction removal efficiency (DRE) for all regulated hazardous contaminants and 99.9999% DRE for dioxins.

WEEE

Equipment Labeling Plans

As per WEEE requirements the equipment is labeled with the dustbin symbol.

Information for Customers and Treatment Facilities

When the last user wishes to discard this product, the information that will guide the customer's action will be available on-line. The disposal information will be made available to the recycler through instructions via Kodak Alaris website.

Information provided to the user in the User Manual includes the meaning of the dustbin symbol, instructions not to dispose as unsorted municipal waste, available collection system and their role in contributing to WEEE goals and potential environmental and health effects as a result of the presence of hazardous substances.